

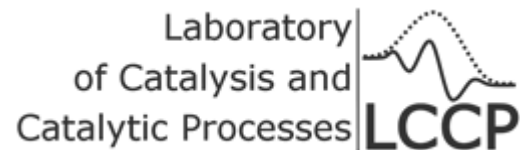

CatalyticFOAM and ISAT for the Efficient Simulation of Fixed Bed Catalytic Reactors

Mauro Bracconi, Alberto Cuoci and Matteo Maestri

Guimarães, June 27th 2016



POLITECNICO
MILANO 1863

Multiscale modeling

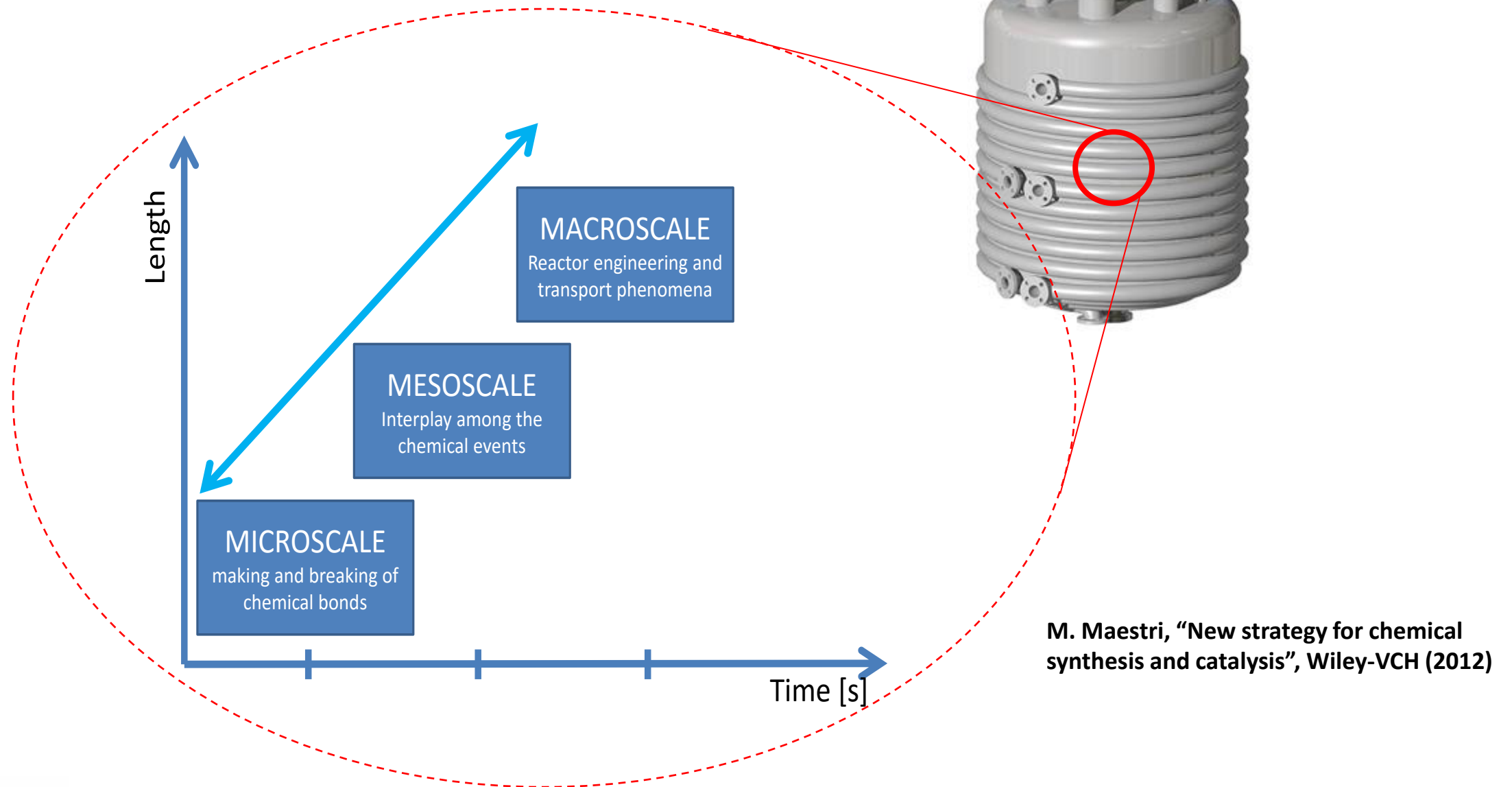

The long way to the active site

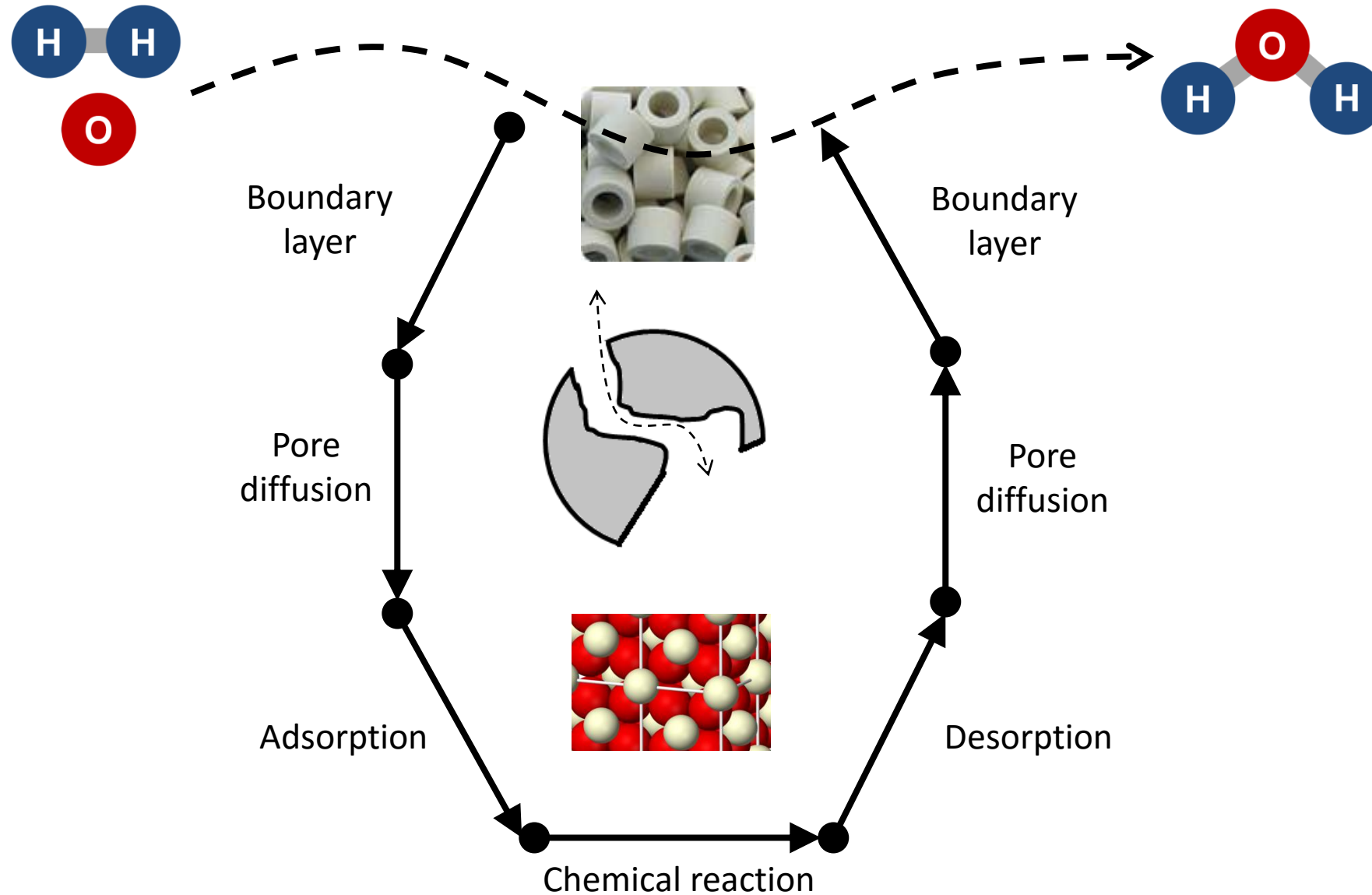

The long way to the active site

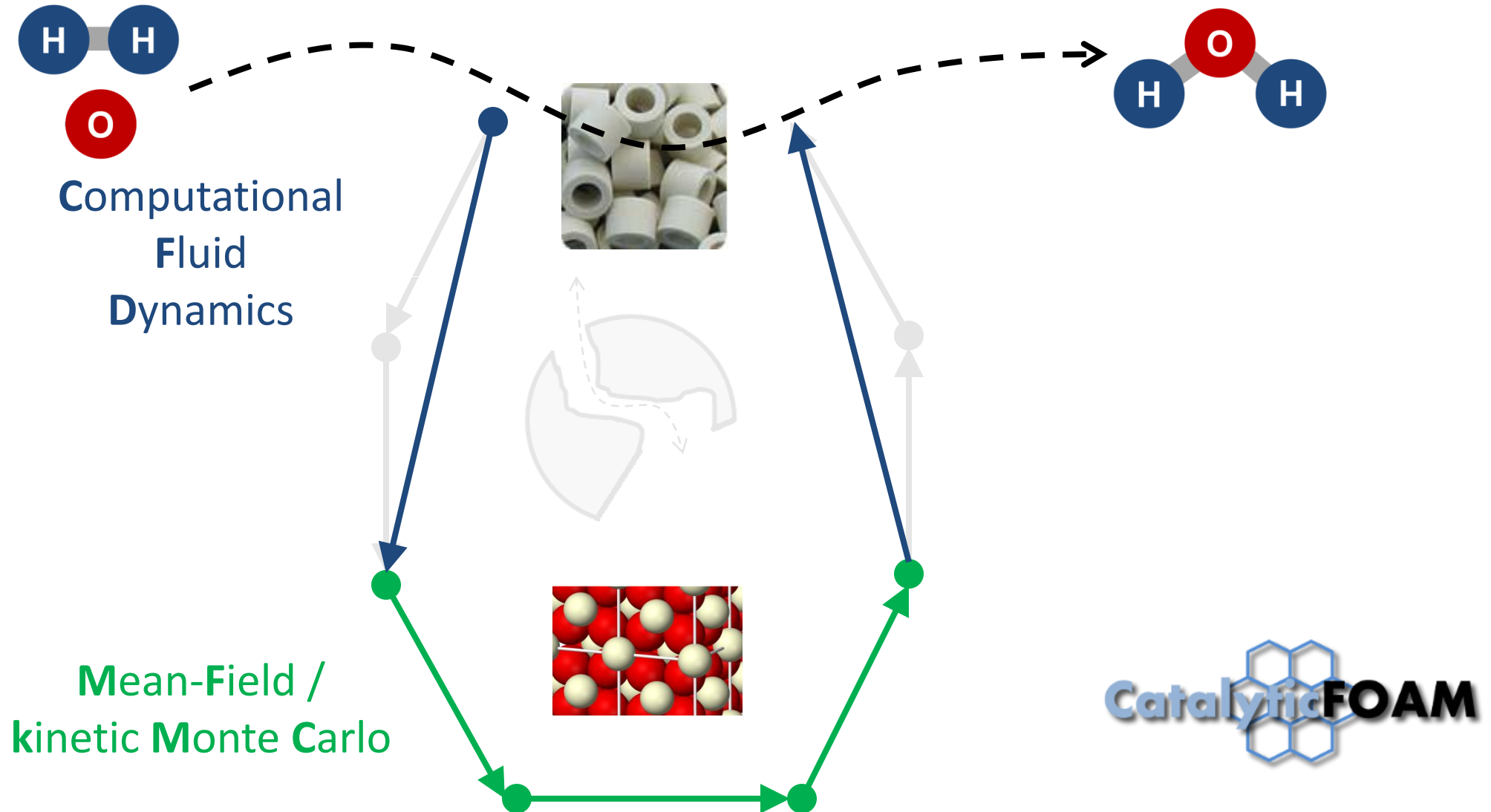

The long way to the active site

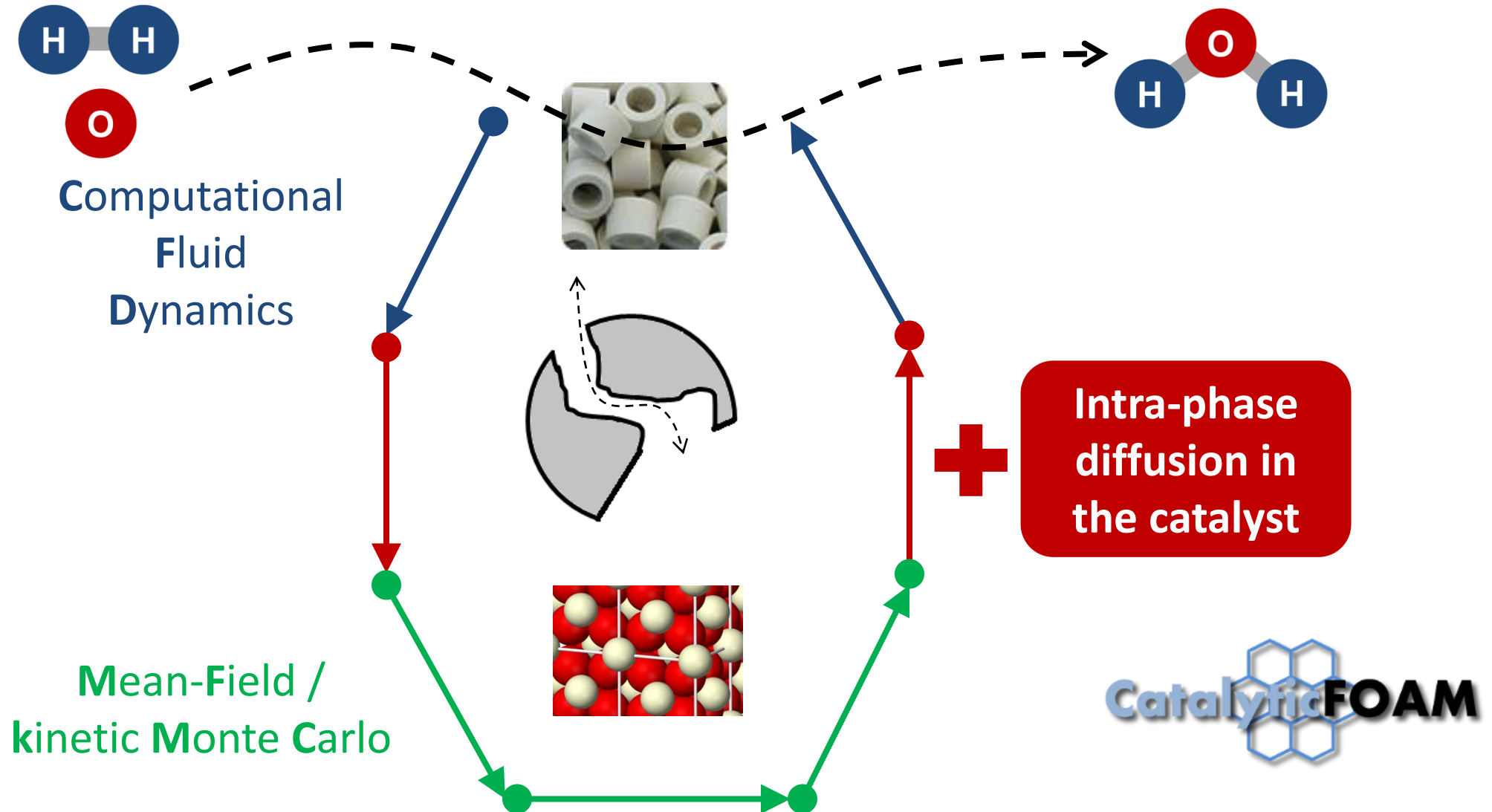

Coupling CFD and microkinetic description of surface reactivity

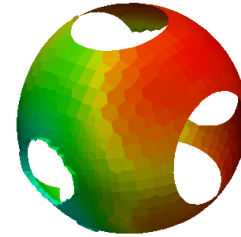
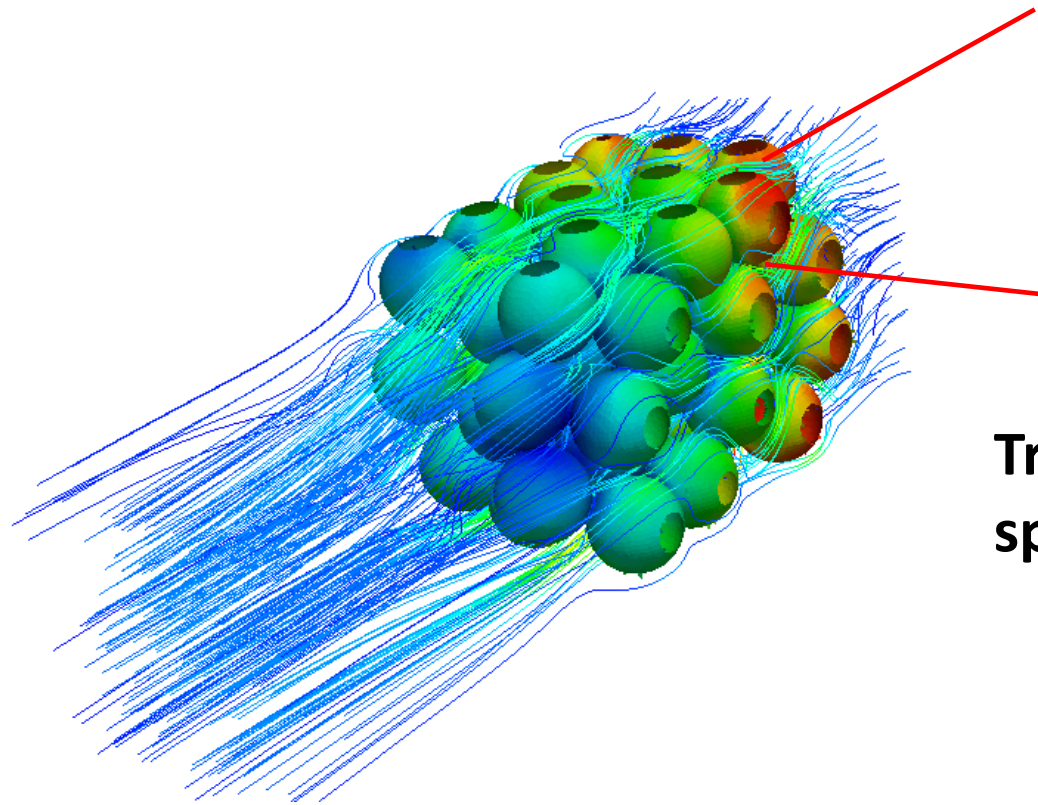

Transient simulation based on operator splitting approach

$$\frac{d\phi(t)}{dt} = M(\phi(t)) + S(\phi(t))$$

set of the species mass fractions and the temperature

rate of change due to transport

rate of change due to chemical reaction

Coupling CFD and microkinetic description of surface reactivity

Computational domain

- 25 particles
- 3D domain
- 500k mesh cells

Operative conditions

- Isothermal
- Feed velocity: 0.35 m/s
- $\text{H}_2\text{O}/\text{CH}_4$: 3.5 : 1

Micro-kinetics model

- 21 gas species
- 13 adsorbed species
- 80 surface reactions

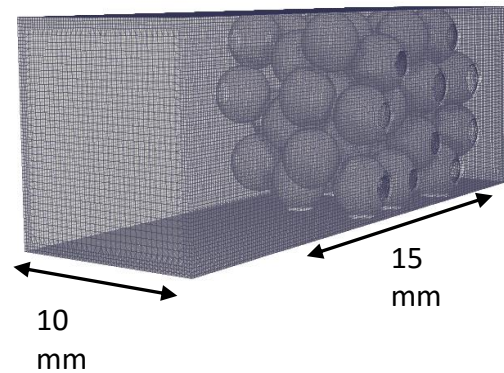

Time = 0.0015 s

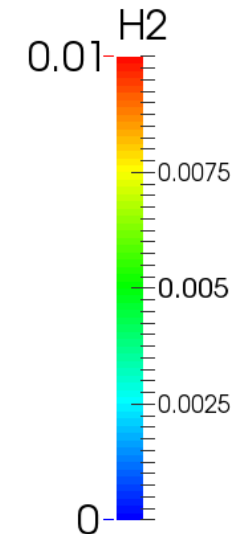
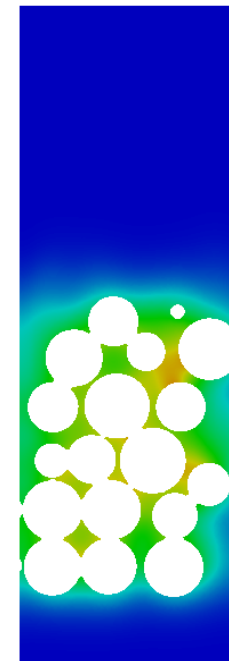
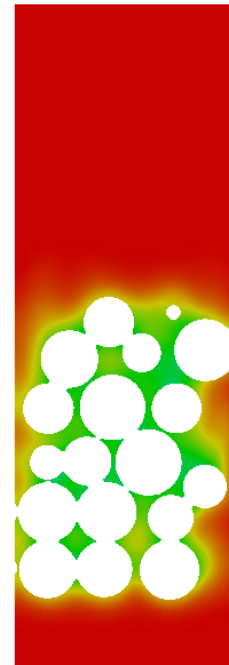
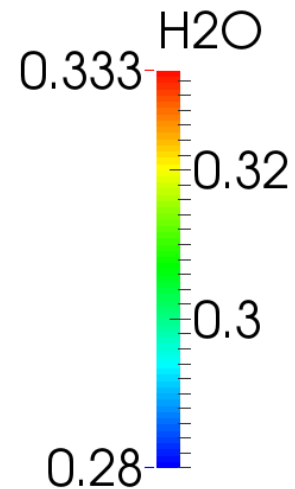

Coupling CFD and microkinetic description of surface reactivity

Computational domain

- 25 particles
- 3D domain
- 500k mesh cells

Operative conditions

- Isothermal
- Feed velocity: 0.35 m/s
- H₂O/CH₄: 3.5 : 1

Micro-kinetics model

- 21 gas species
- 13 adsorbed species
- 80 surface reactions

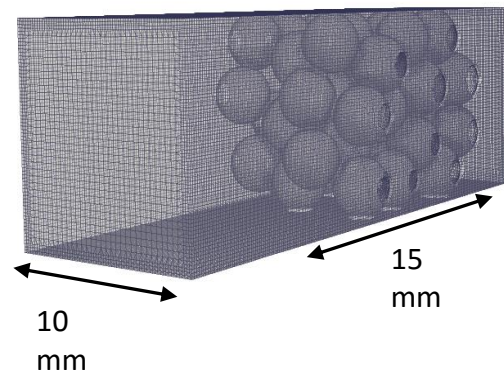

Time = 0.0015 s

~350 hours for the simulation of 0.0015 s

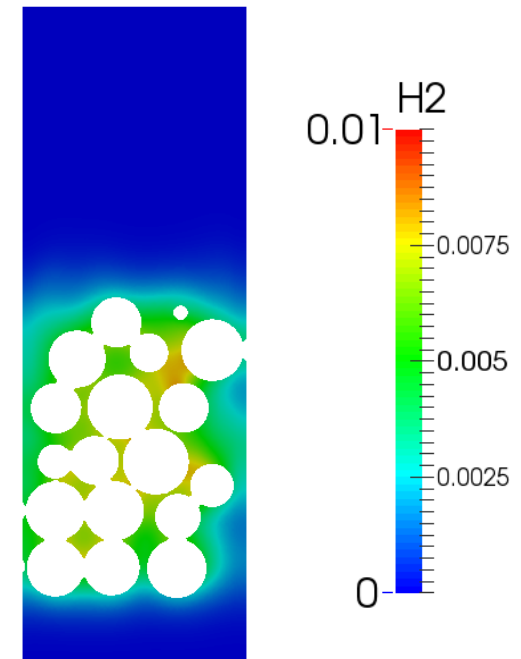

Most of the computational time spent in solution of chemistry

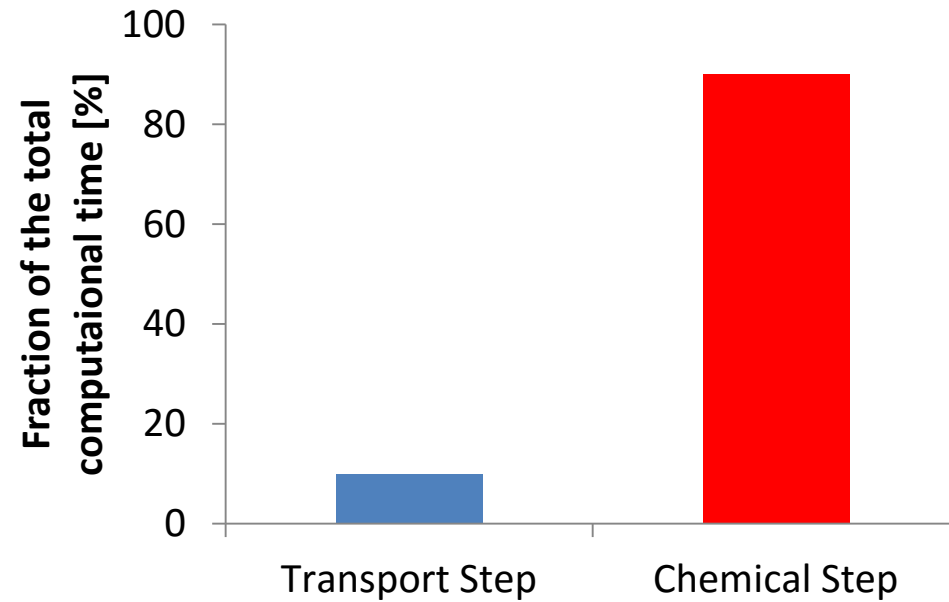

Most of the computational time spent in solution of chemistry

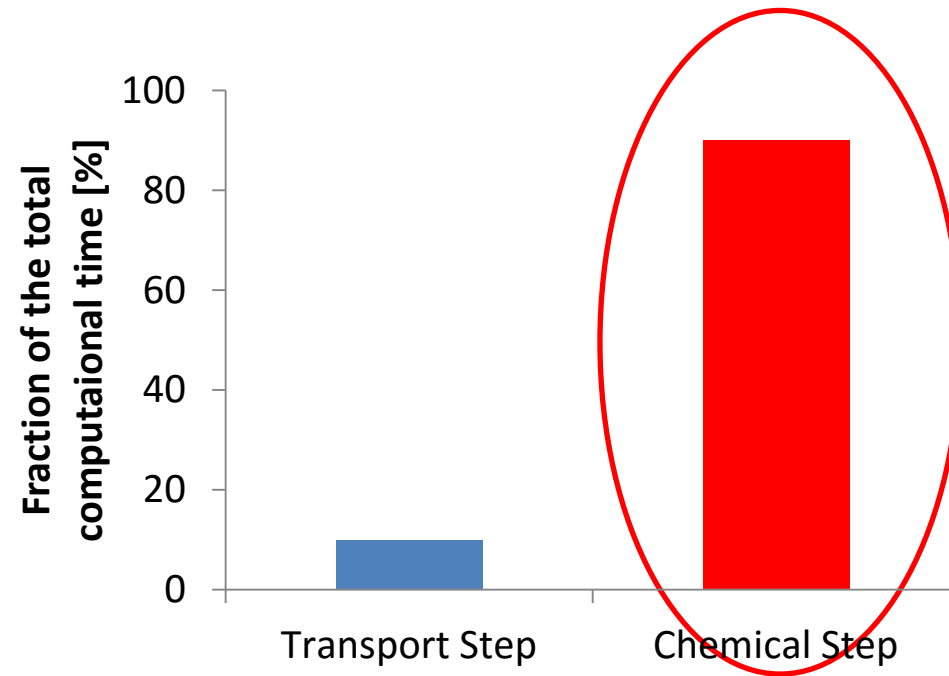

Most of the computational time spent in solution of chemistry

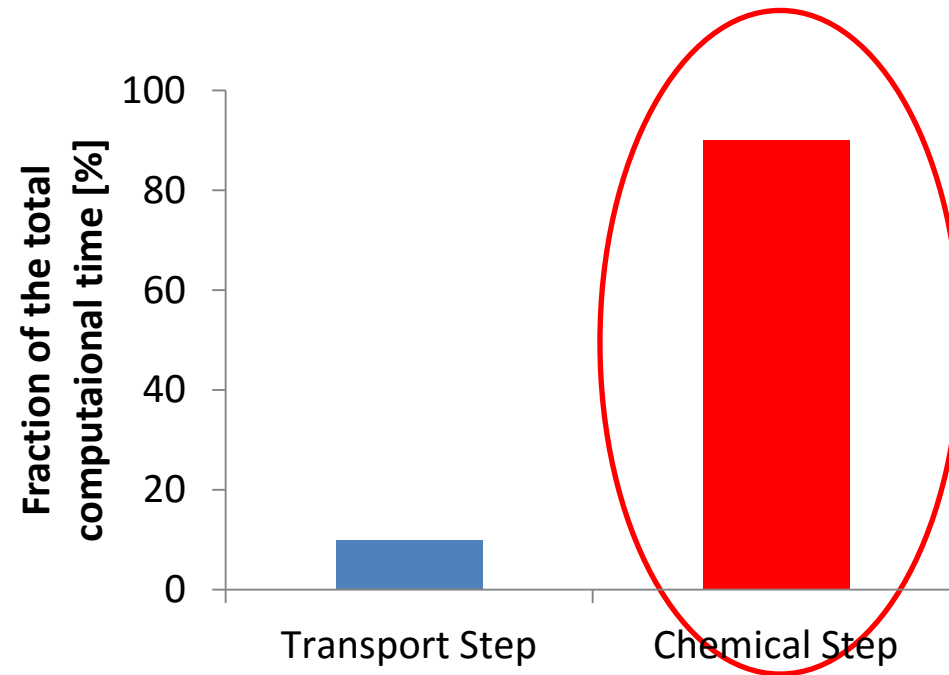

**Speed-up of the
chemical step**

Why so expensive?

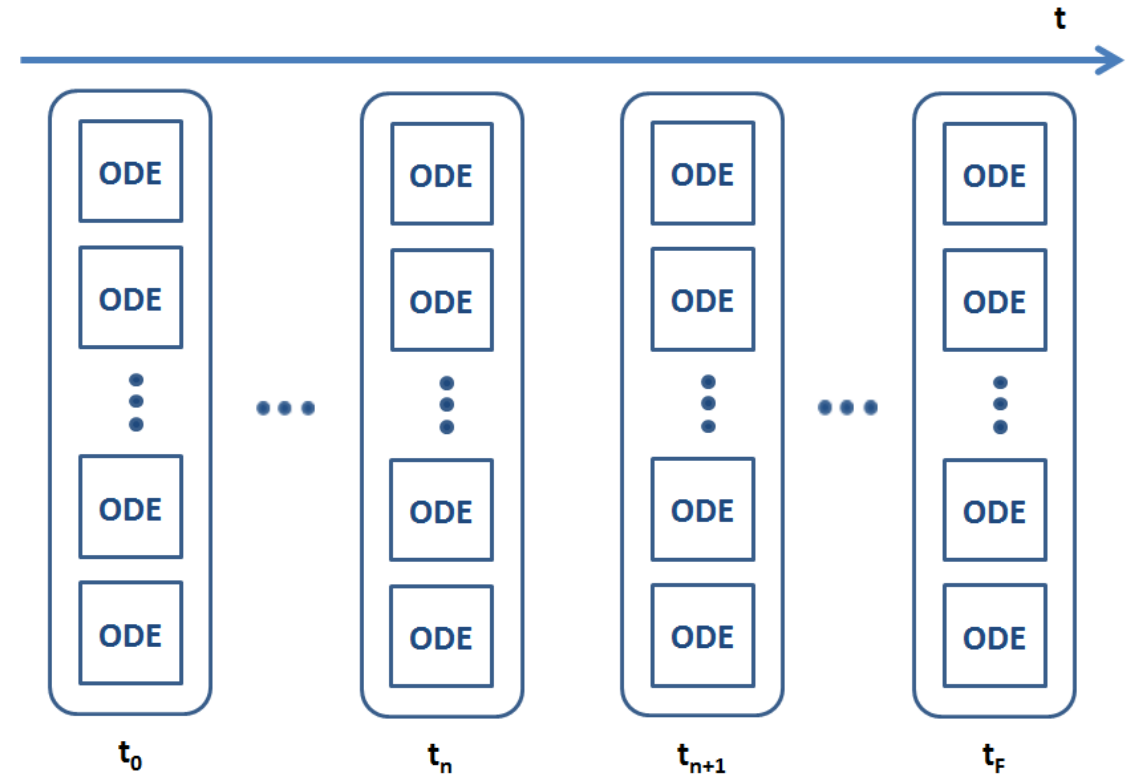
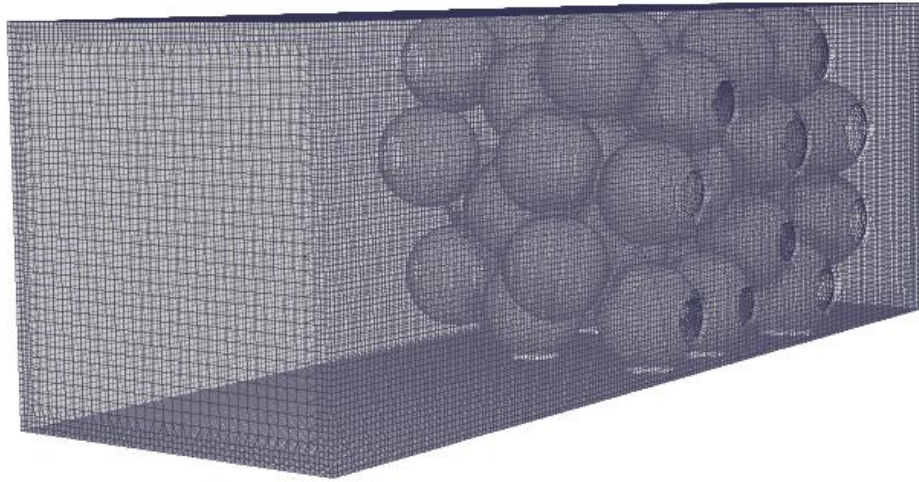

Why so expensive?

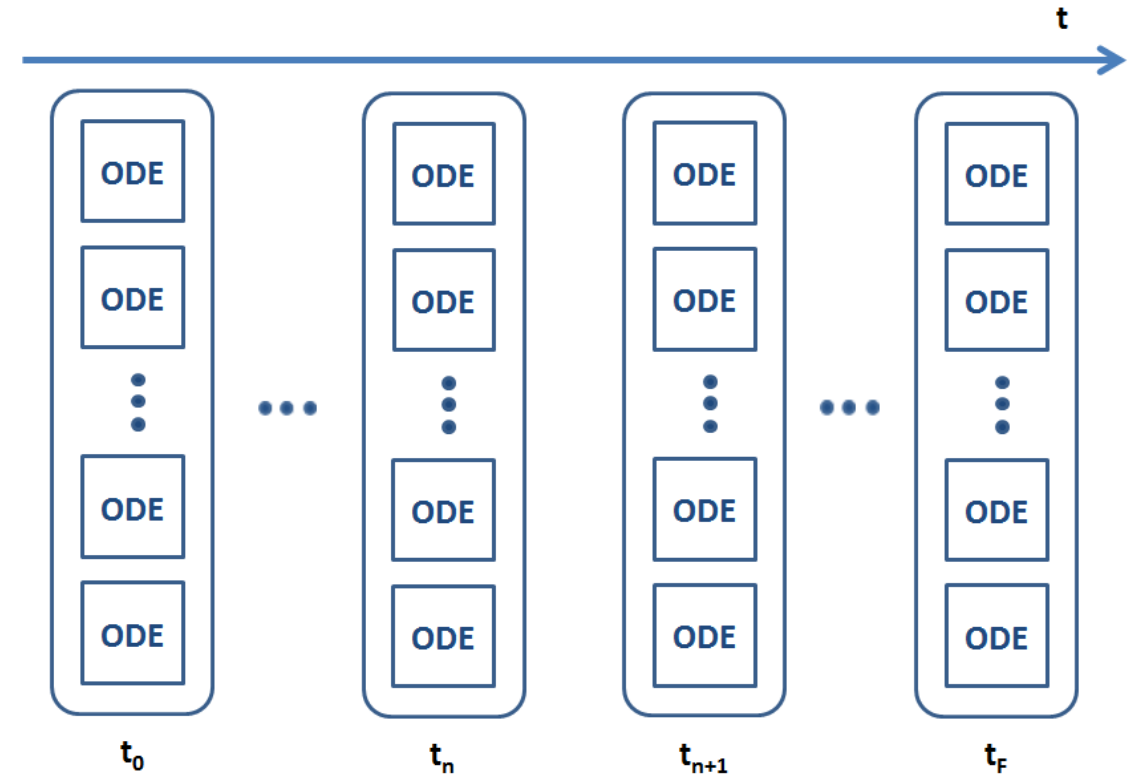
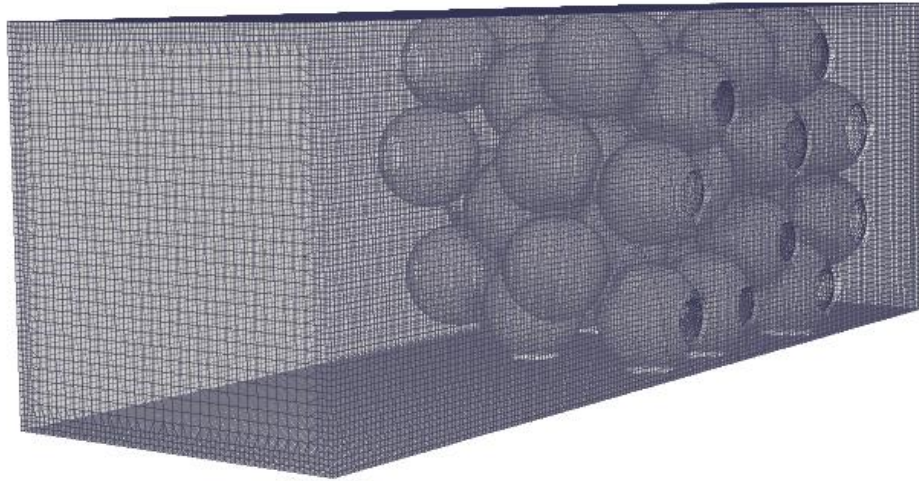

ISAT

How does it work?

ODE_0

How does it work?

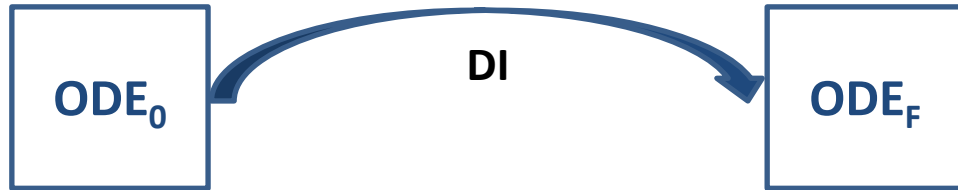

How does it work?

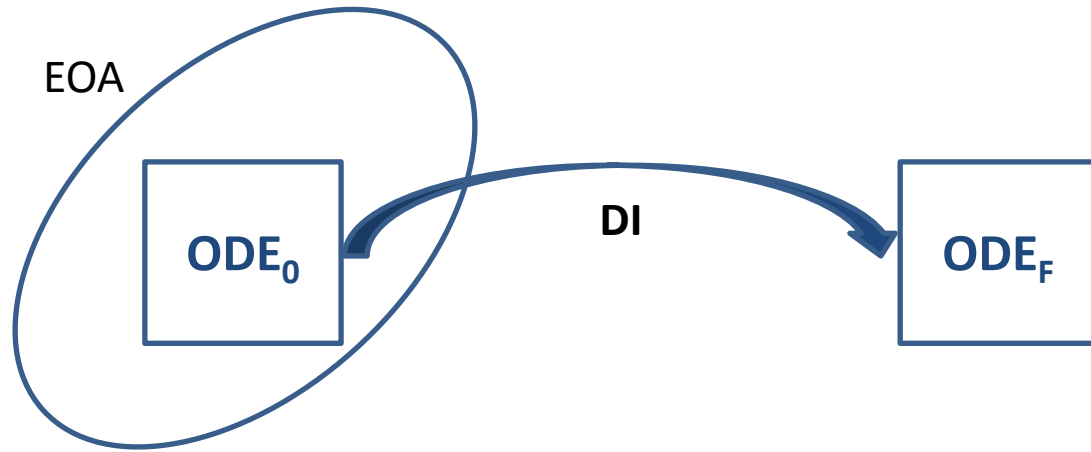

The ODE systems whose initial condition falls inside the EOA could be solved by extrapolating the results of this one with an error at most of ϵ_{tol}

addition



How does it work?

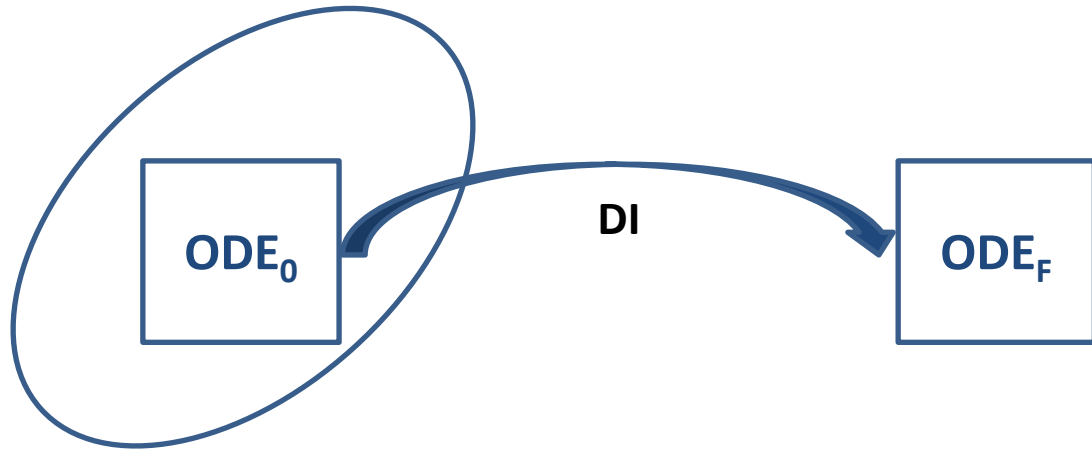

How does it work?

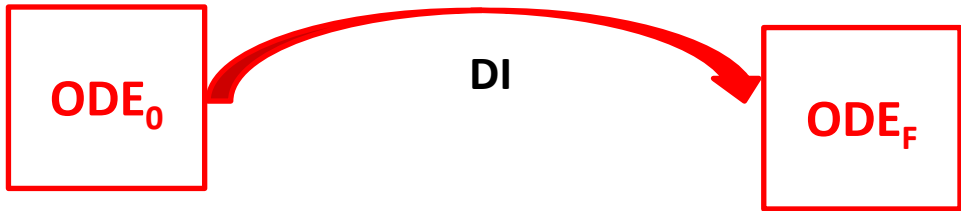
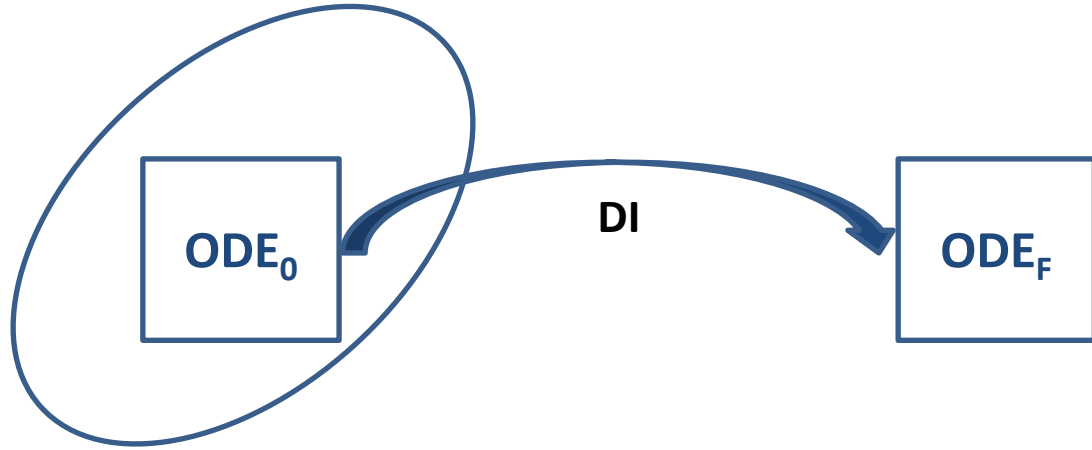

How does it work?

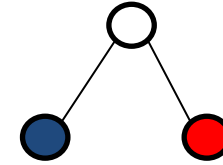
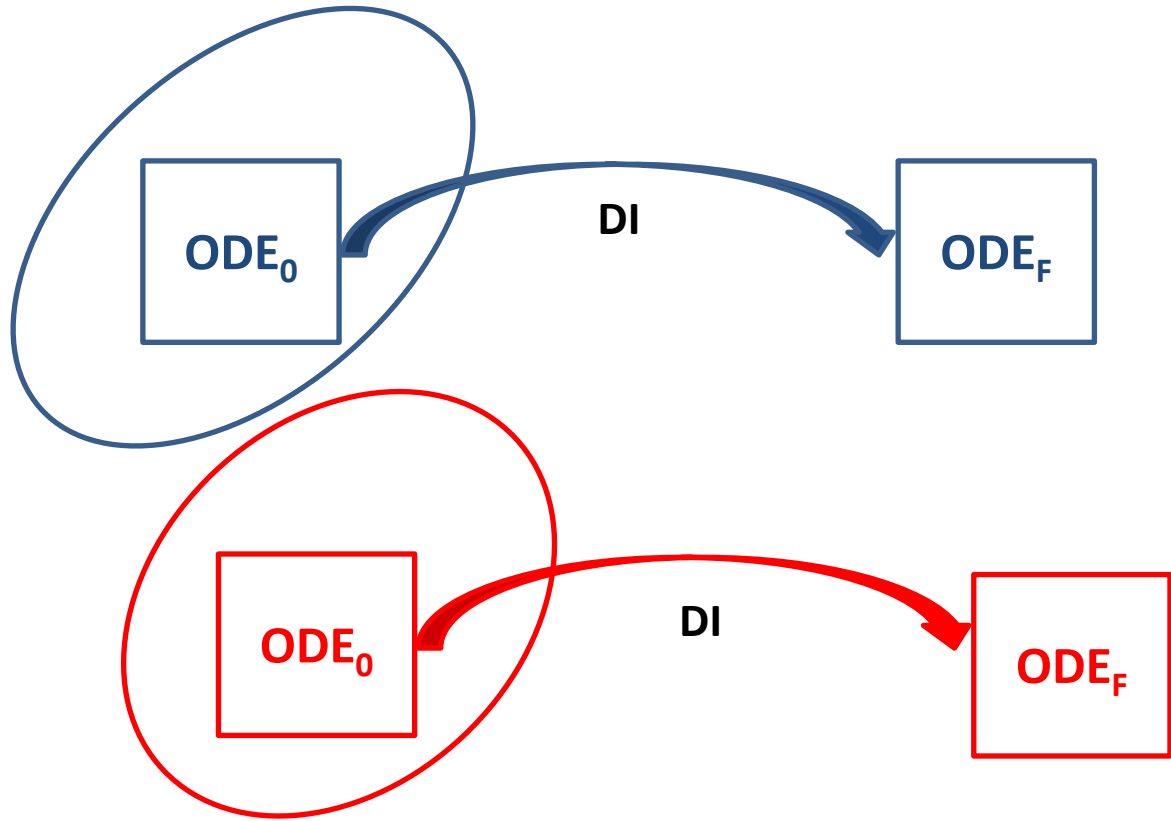

Storage table in the form of a binary tree

How does it work?

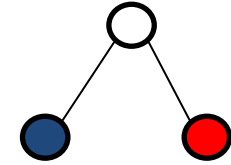
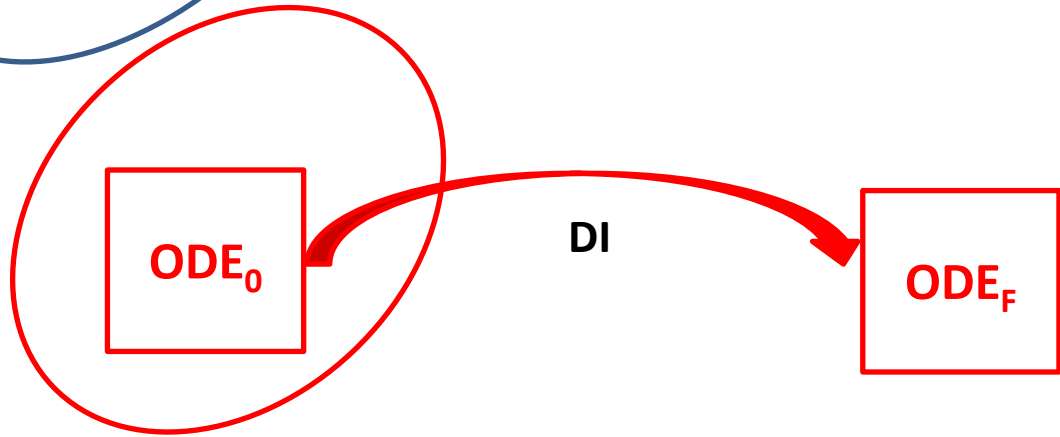
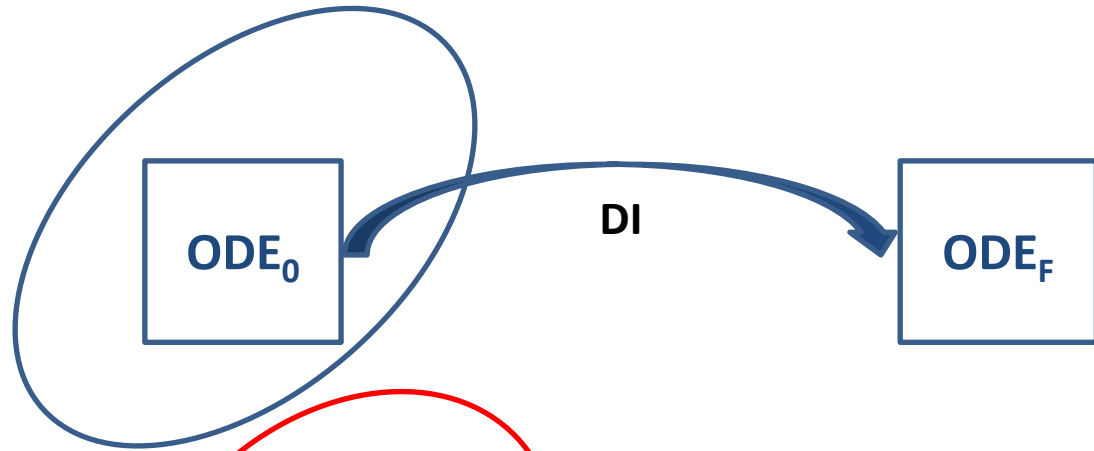

How does it work?

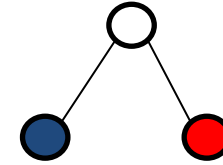
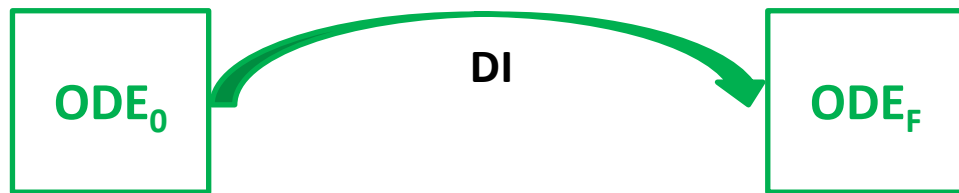
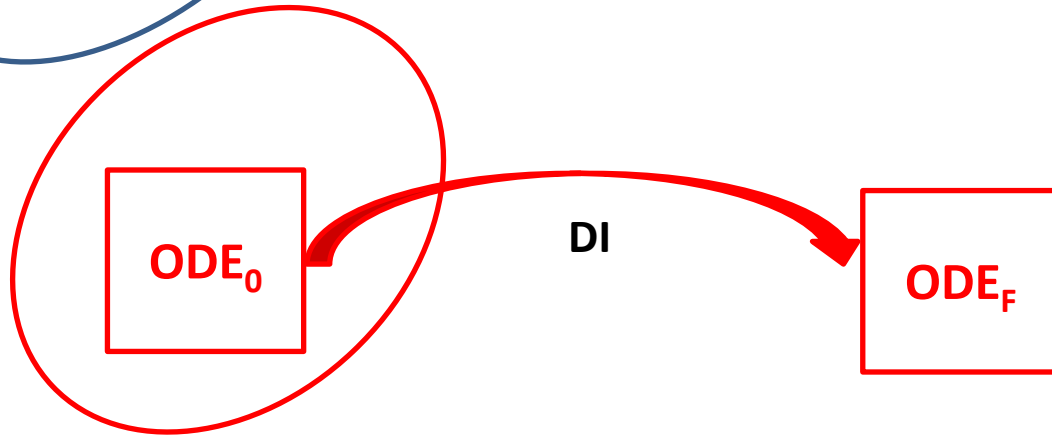
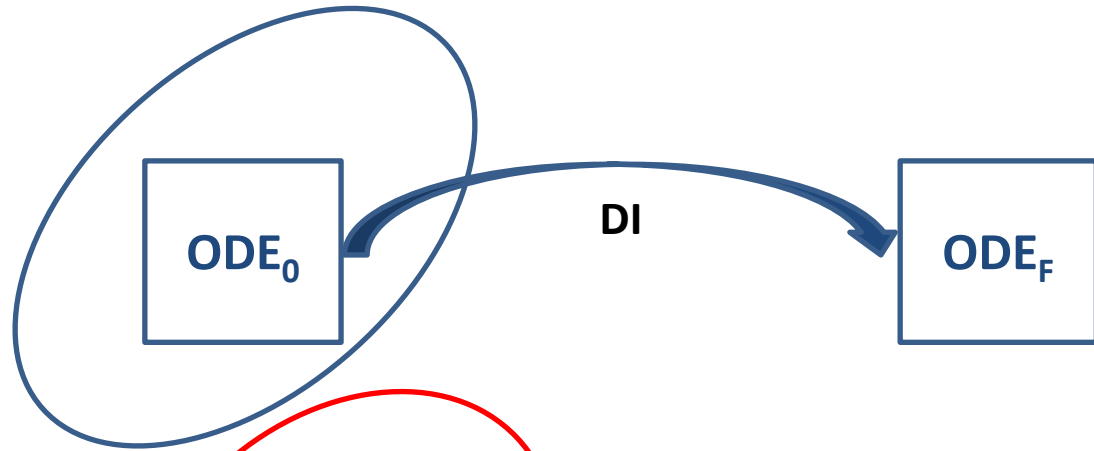

How does it work?

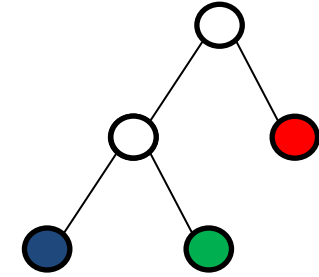
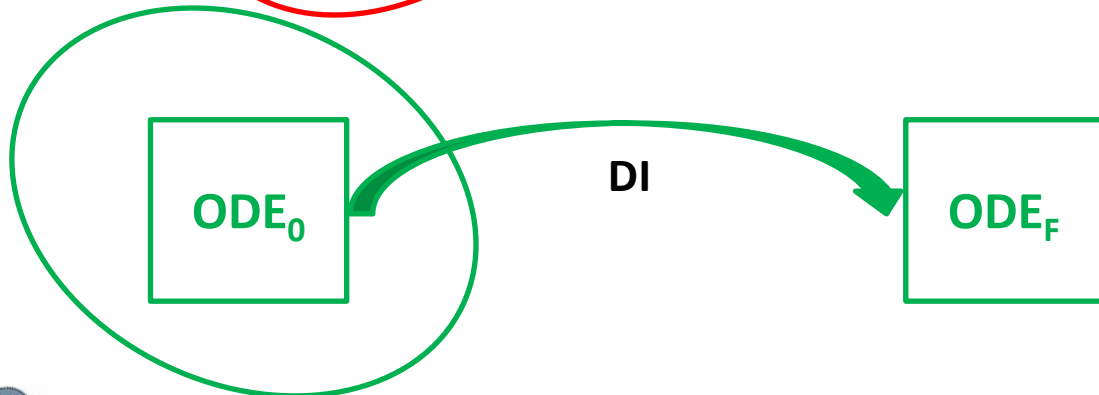
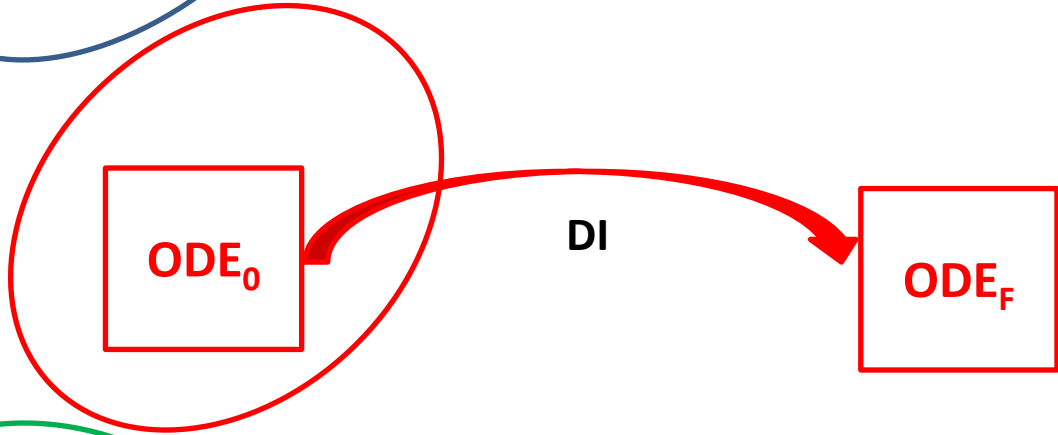
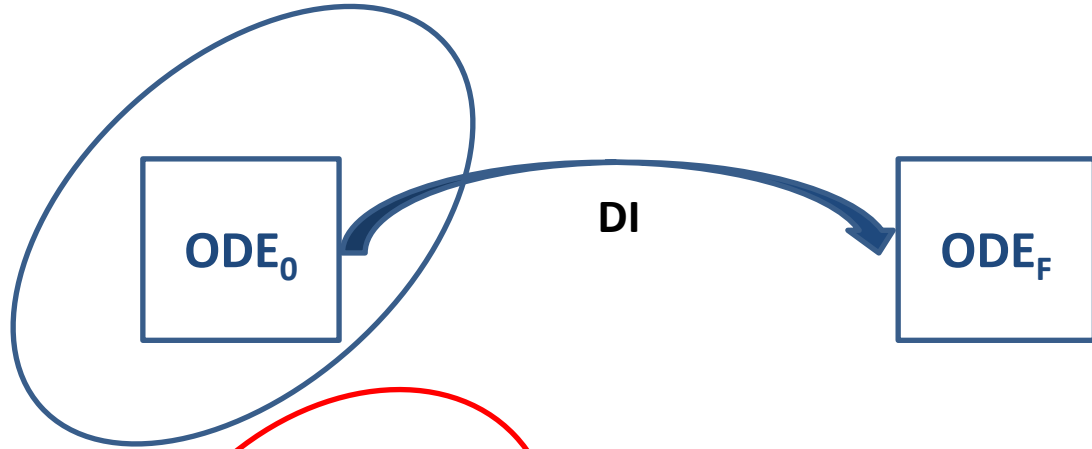

ISAT table is built during the simulation ("in situ")

How does it work?

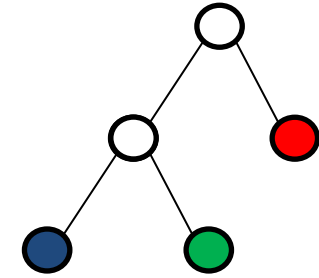
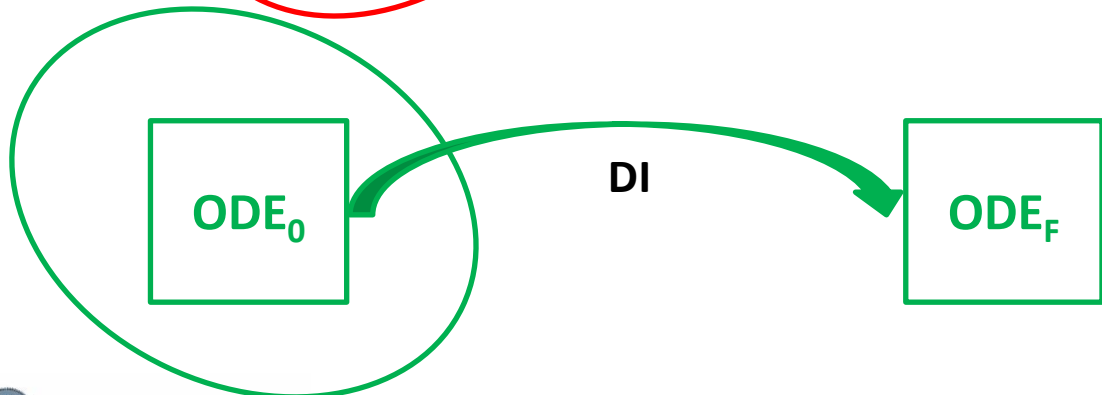
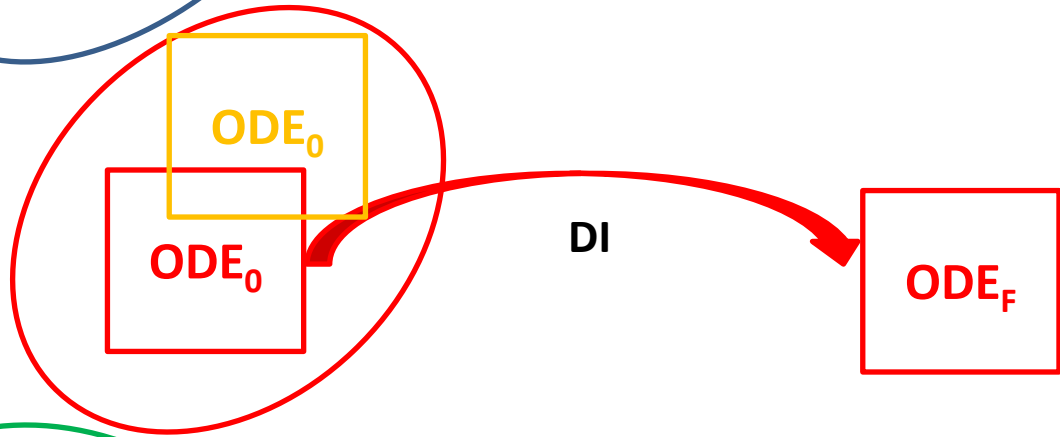
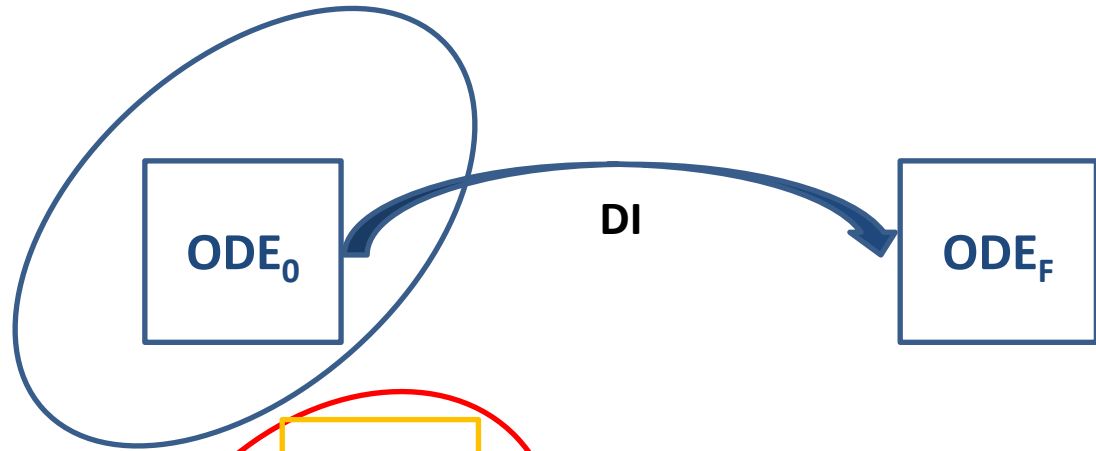

How does it work?

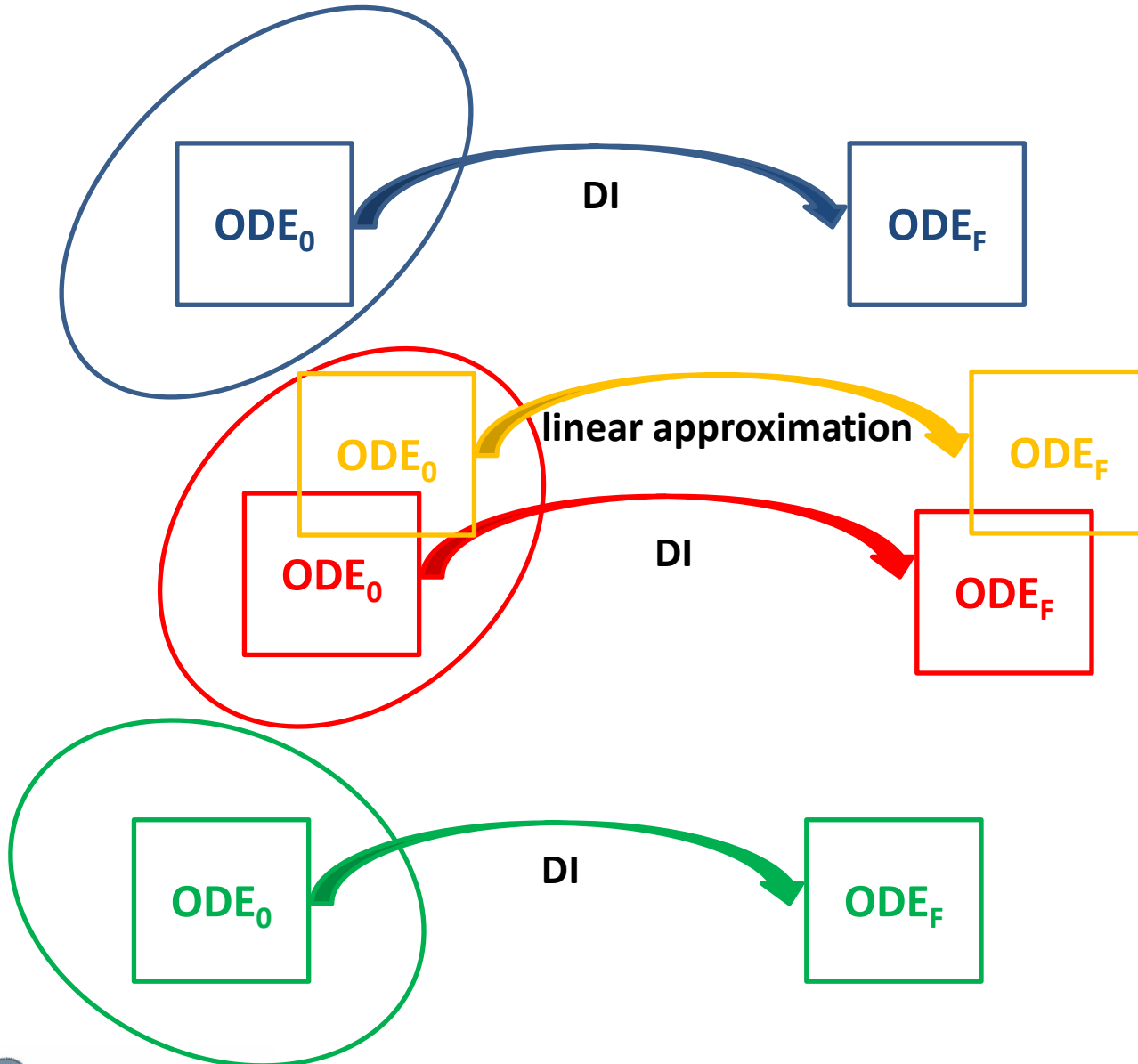

retrieval

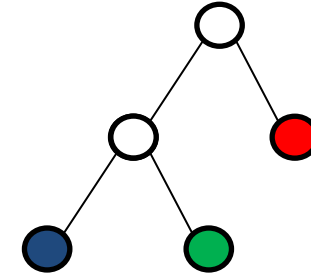

The information recovered during previous integration are exploited to approximate the ODE solution

How does it work?

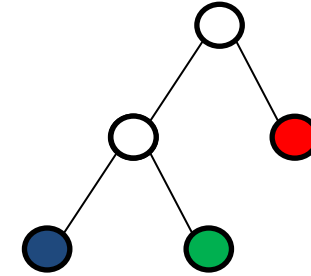
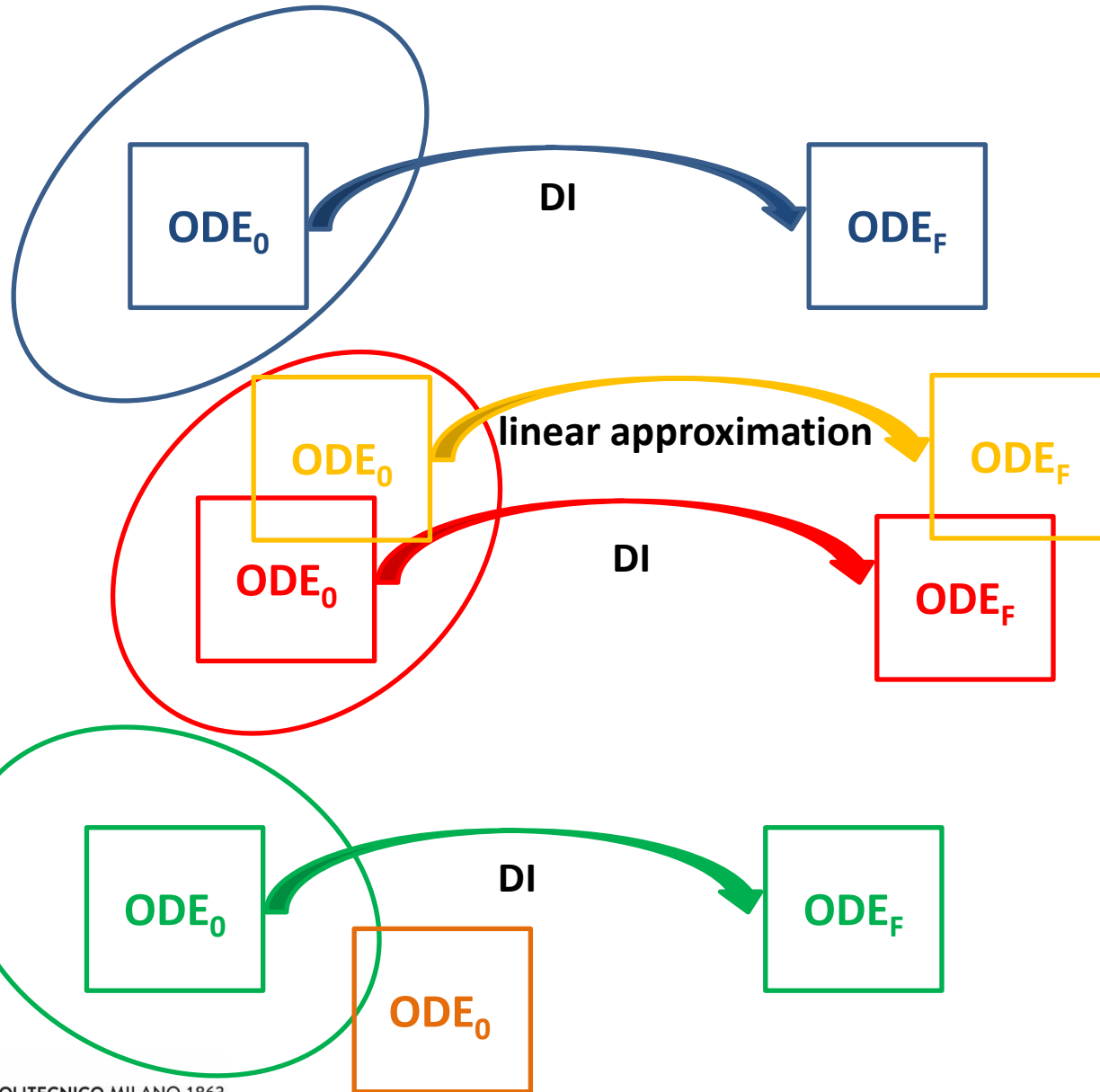

How does it work?

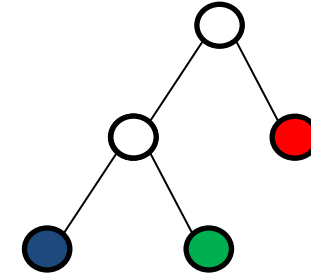
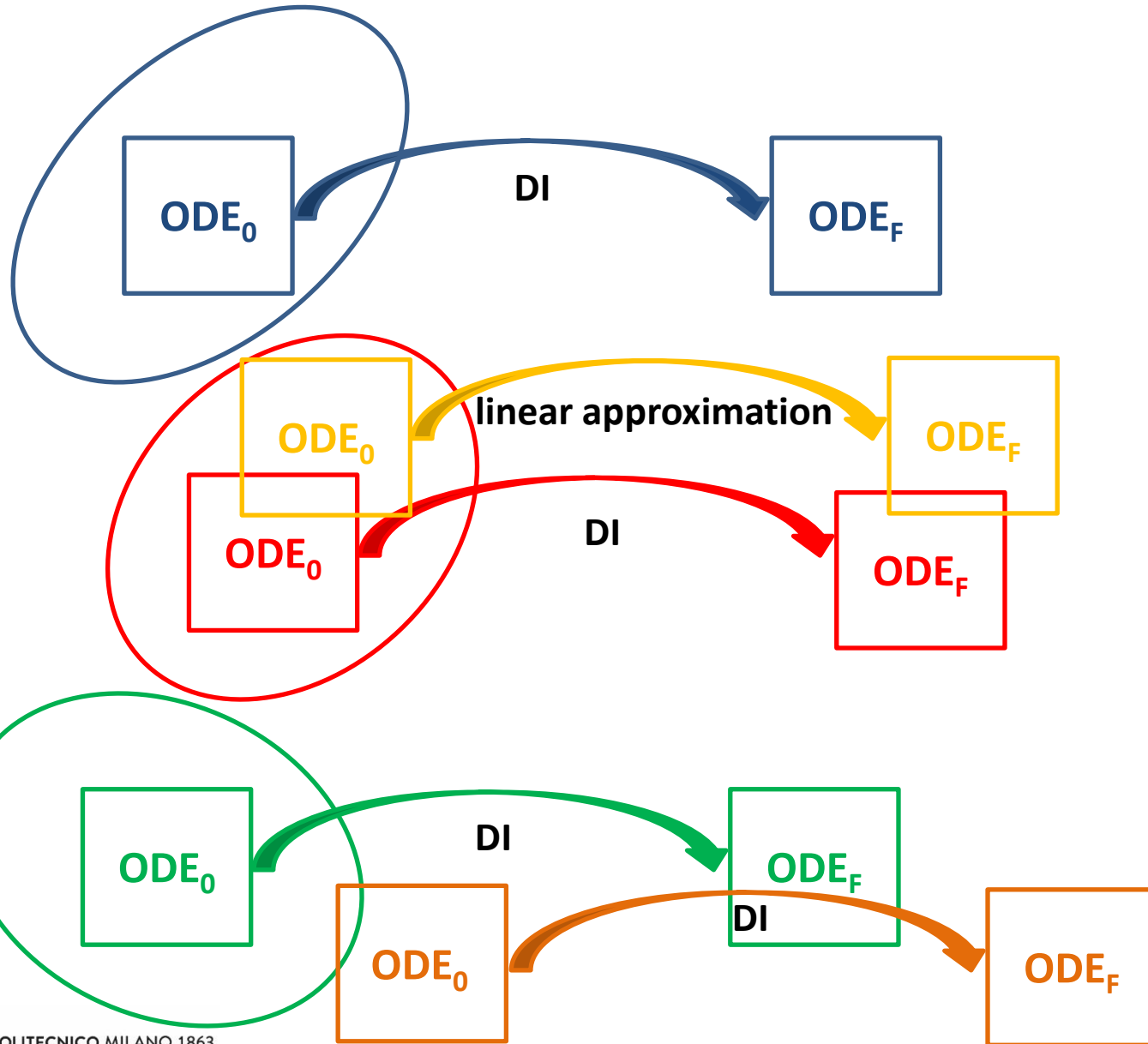

How does it work?

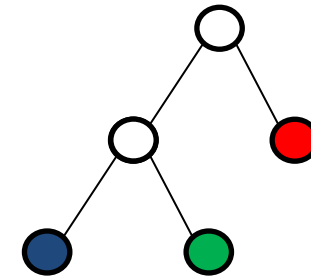
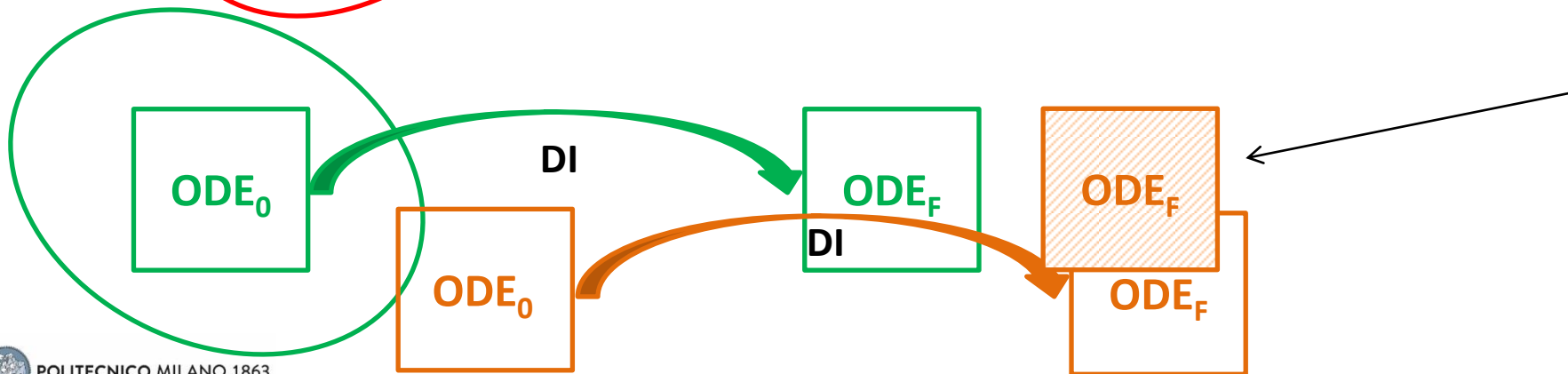
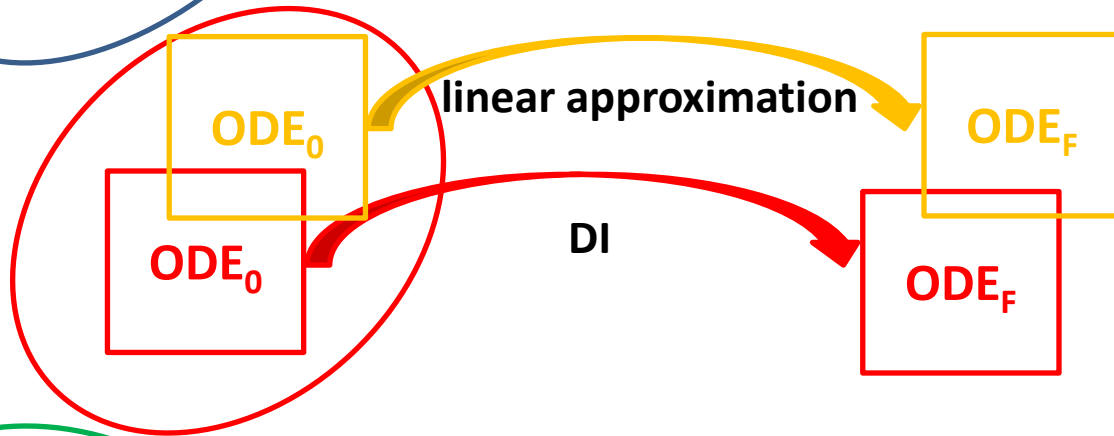
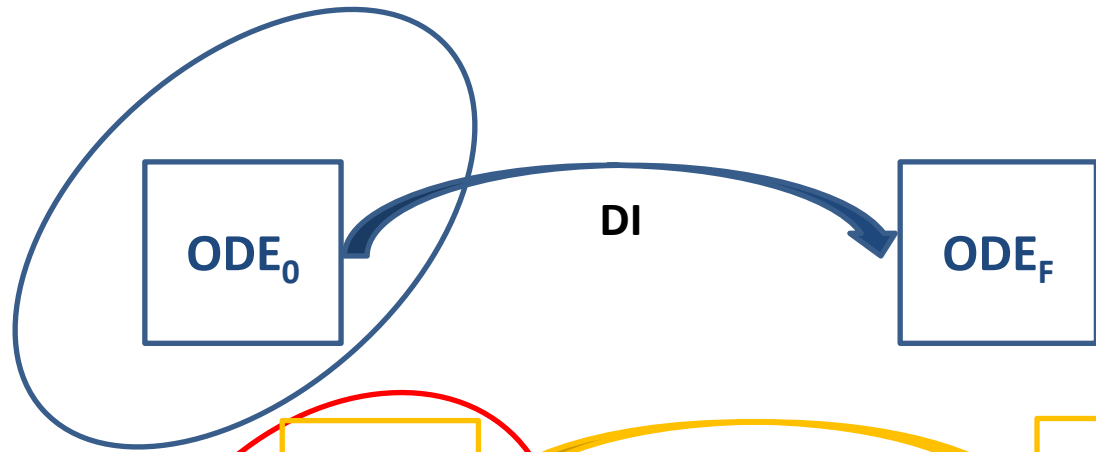

Evaluated by
linear
approximation

How does it work?

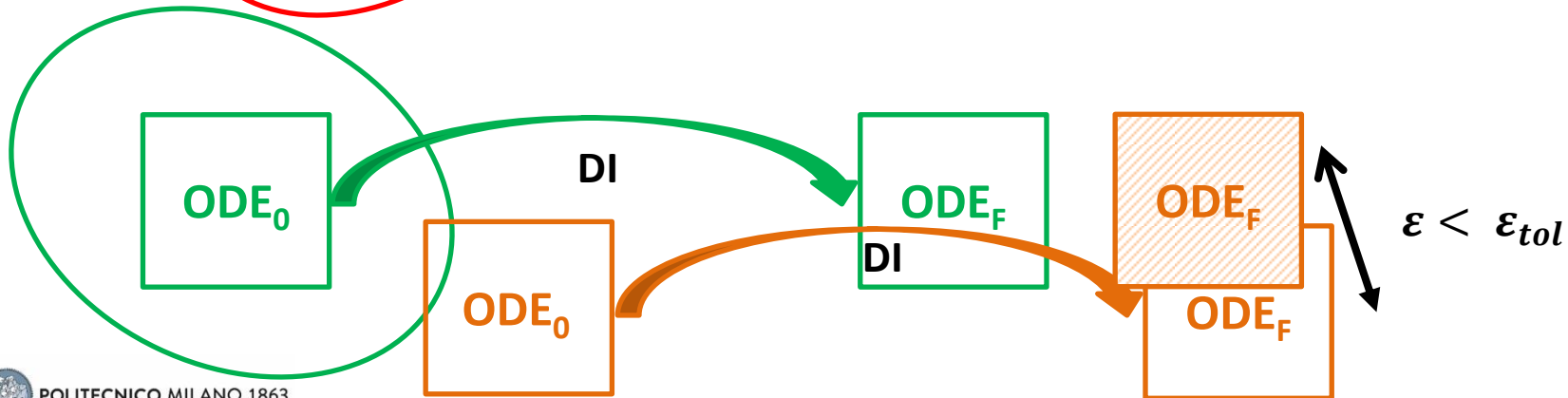
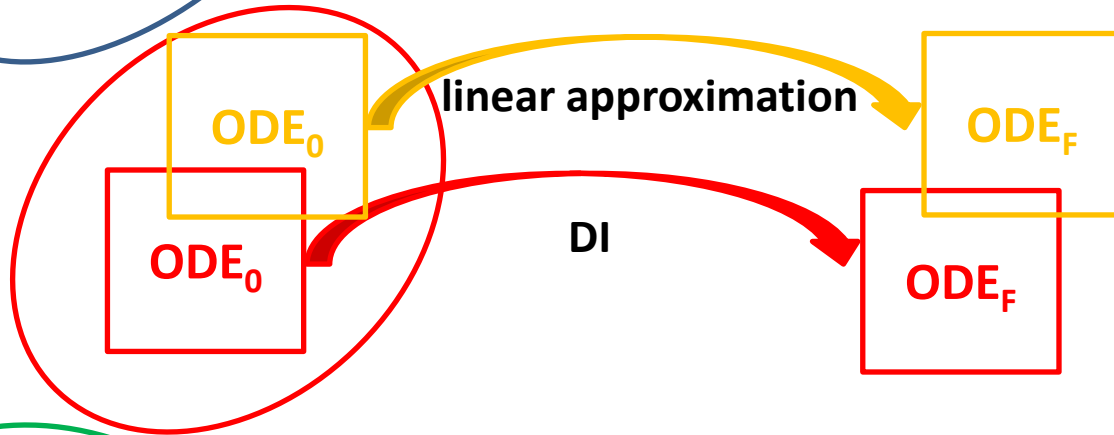
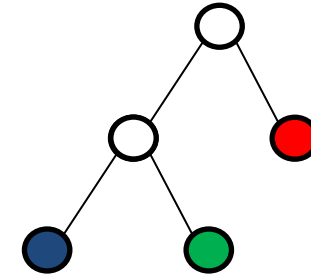
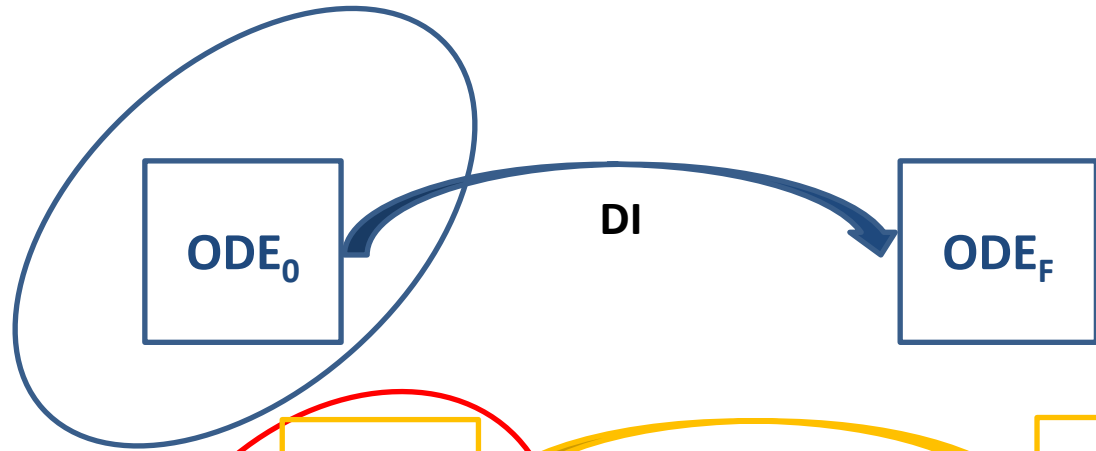

The approximation error is evaluated and if lower than ϵ_{tol} the EOA grows to cover the query

How does it work?

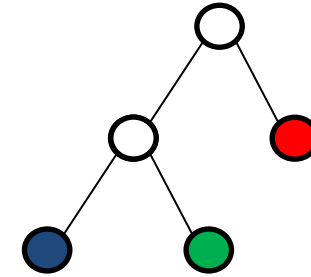
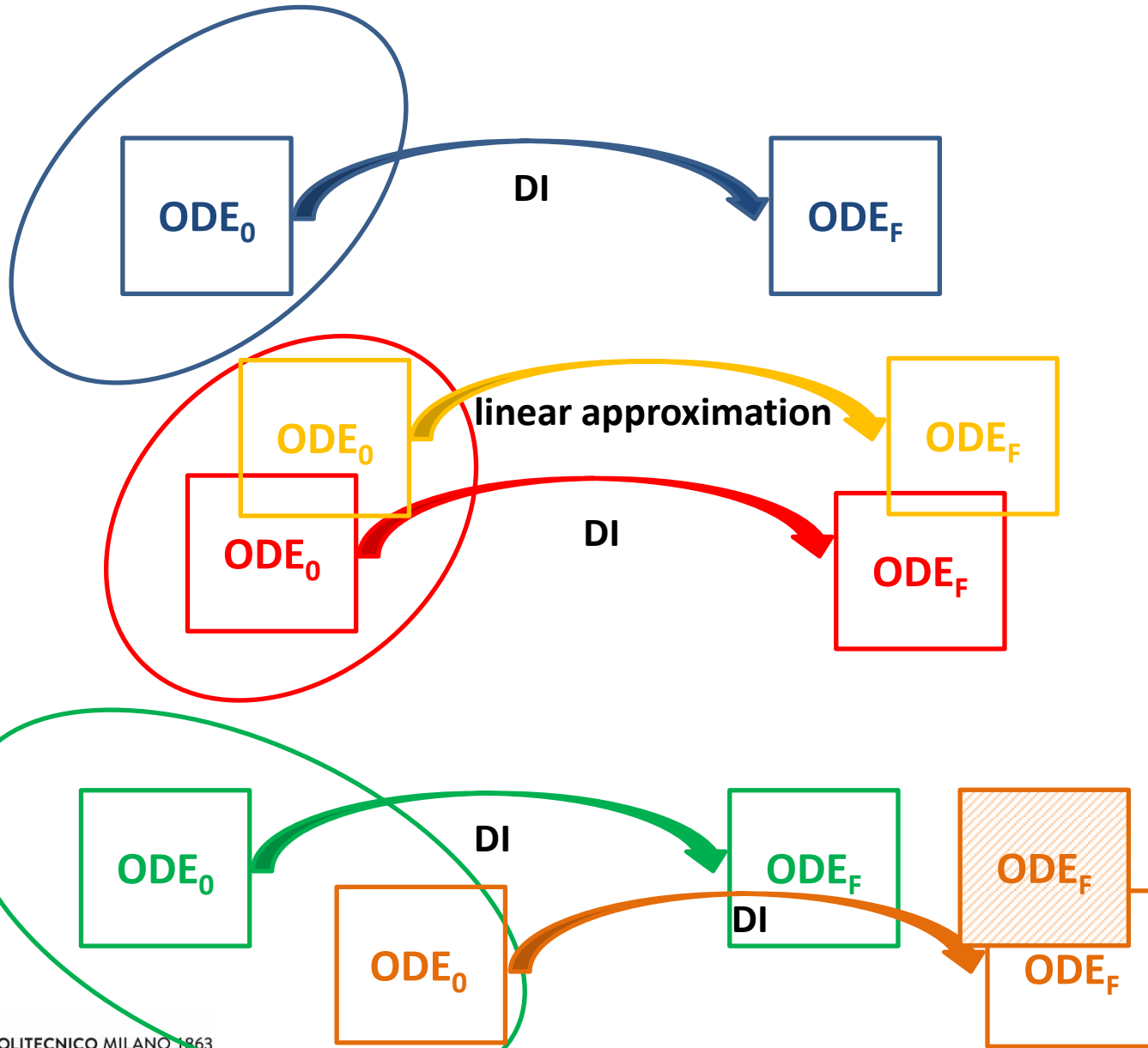

growth

Numerical library

- A C++ library implementing the algorithm has been developed

Numerical library

- A C++ library implementing the algorithm has been developed
- Specific techniques has been adopted to deal with transient problems:
 - Periodical deletion of infrequently accessed records
 - Periodical reshaping of the binary tree to keep searching procedure efficient

Numerical library

- A C++ library implementing the algorithm has been developed
- Specific techniques has been adopted to deal with transient problems:
 - Periodical deletion of infrequently accessed records
 - Periodical reshaping of the binary tree to keep searching procedure efficient
- General structure in order to be interfaced with any CFD code exploiting the operating splitting technique

Implementation in CFD numerical framework

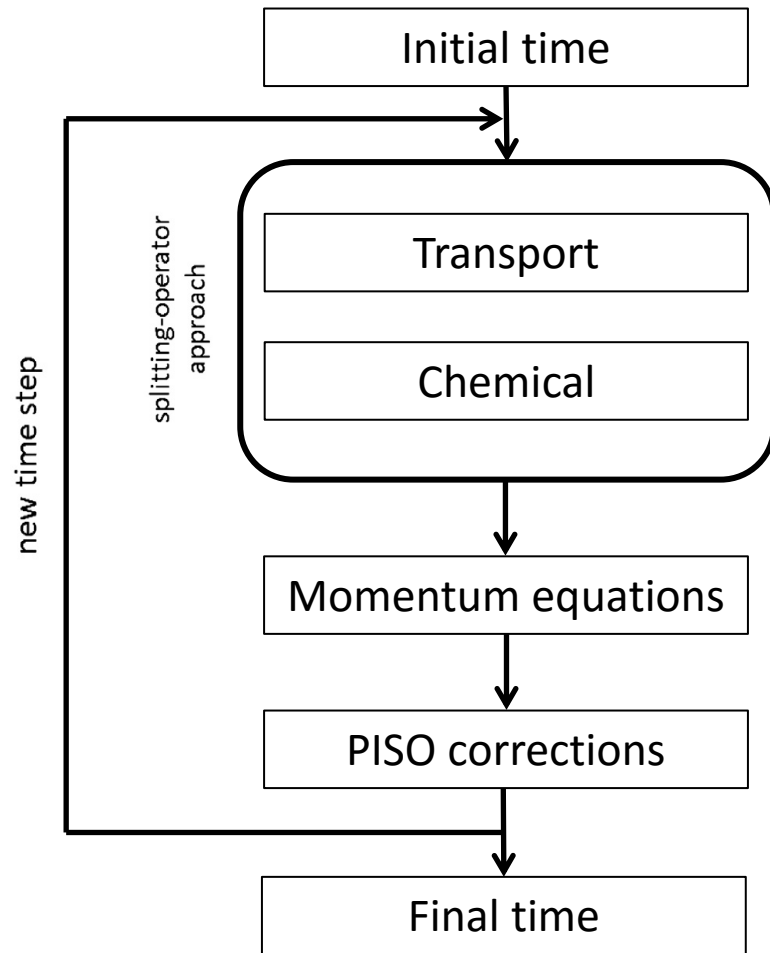

Implementation in CFD numerical framework

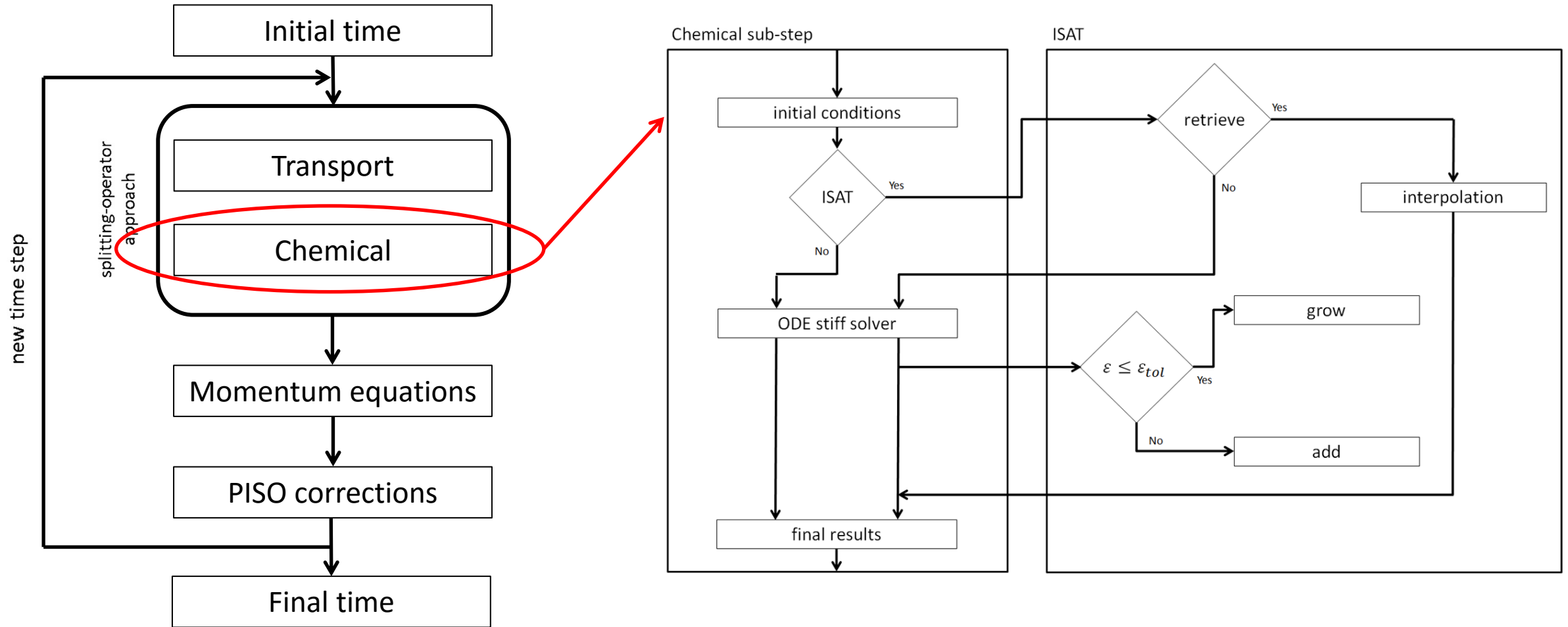

Algorithm validation

- Circular reactor
- Isothermal and adiabatic simulations
- Hydrogen combustion and methane catalytic partial oxidation over Rh
- Several operating conditions

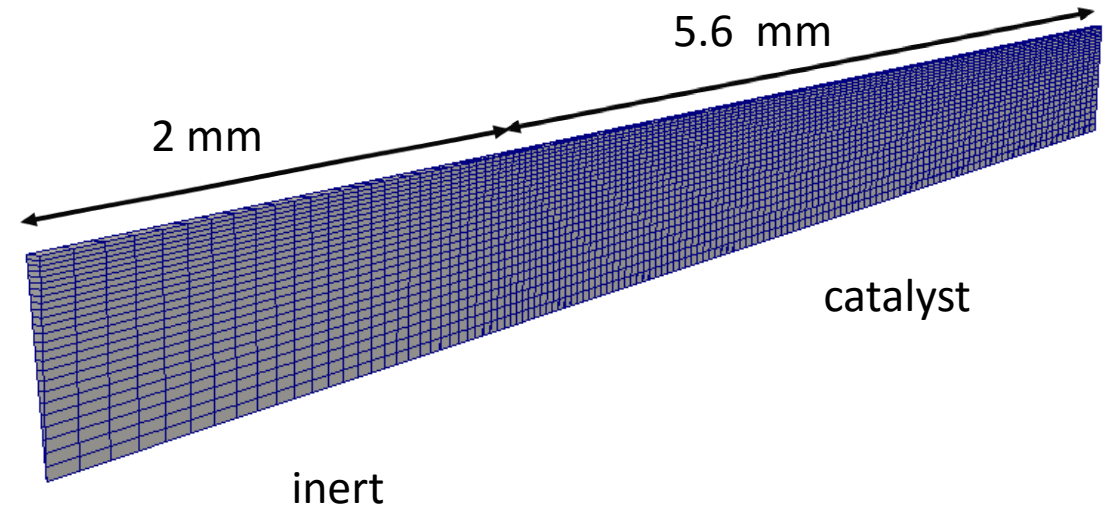

Algorithm validation

- Circular reactor
- Isothermal and adiabatic simulations
- Hydrogen combustion and methane catalytic partial oxidation over Rh
- Several operating conditions

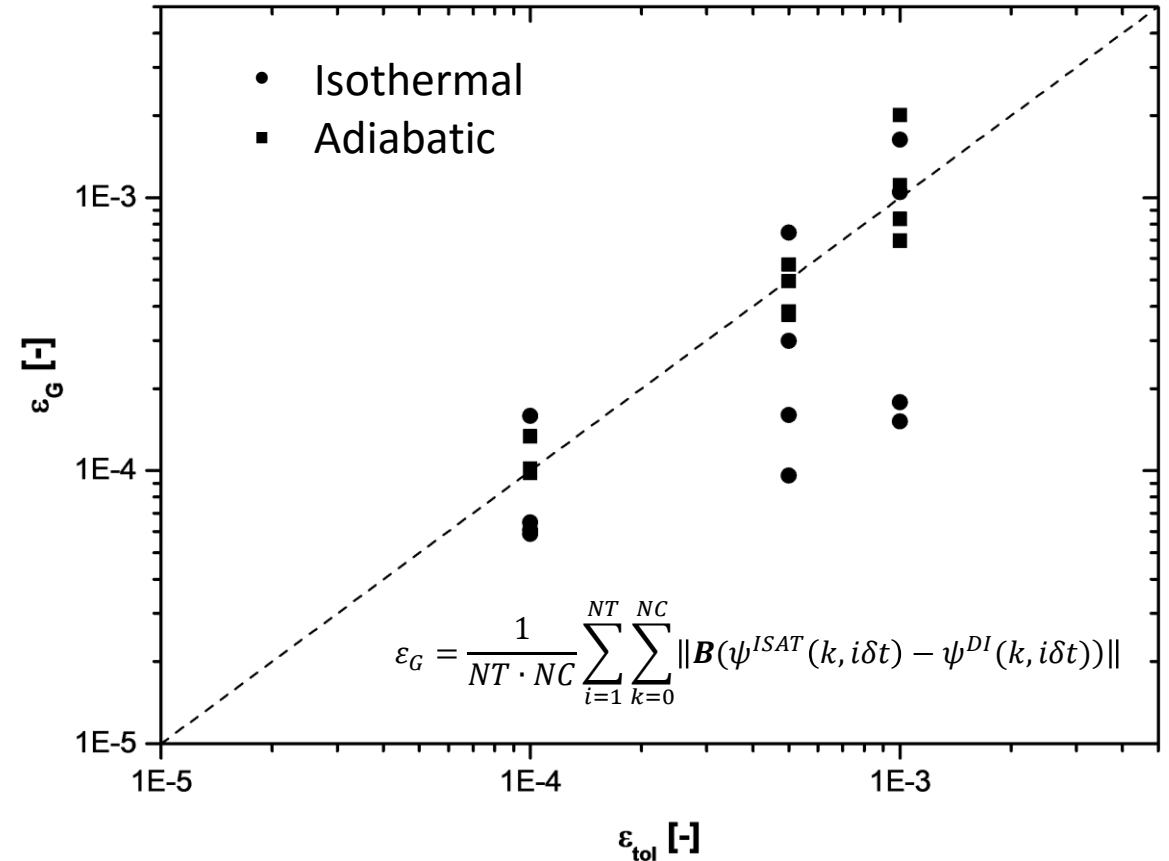

Computational efficiency

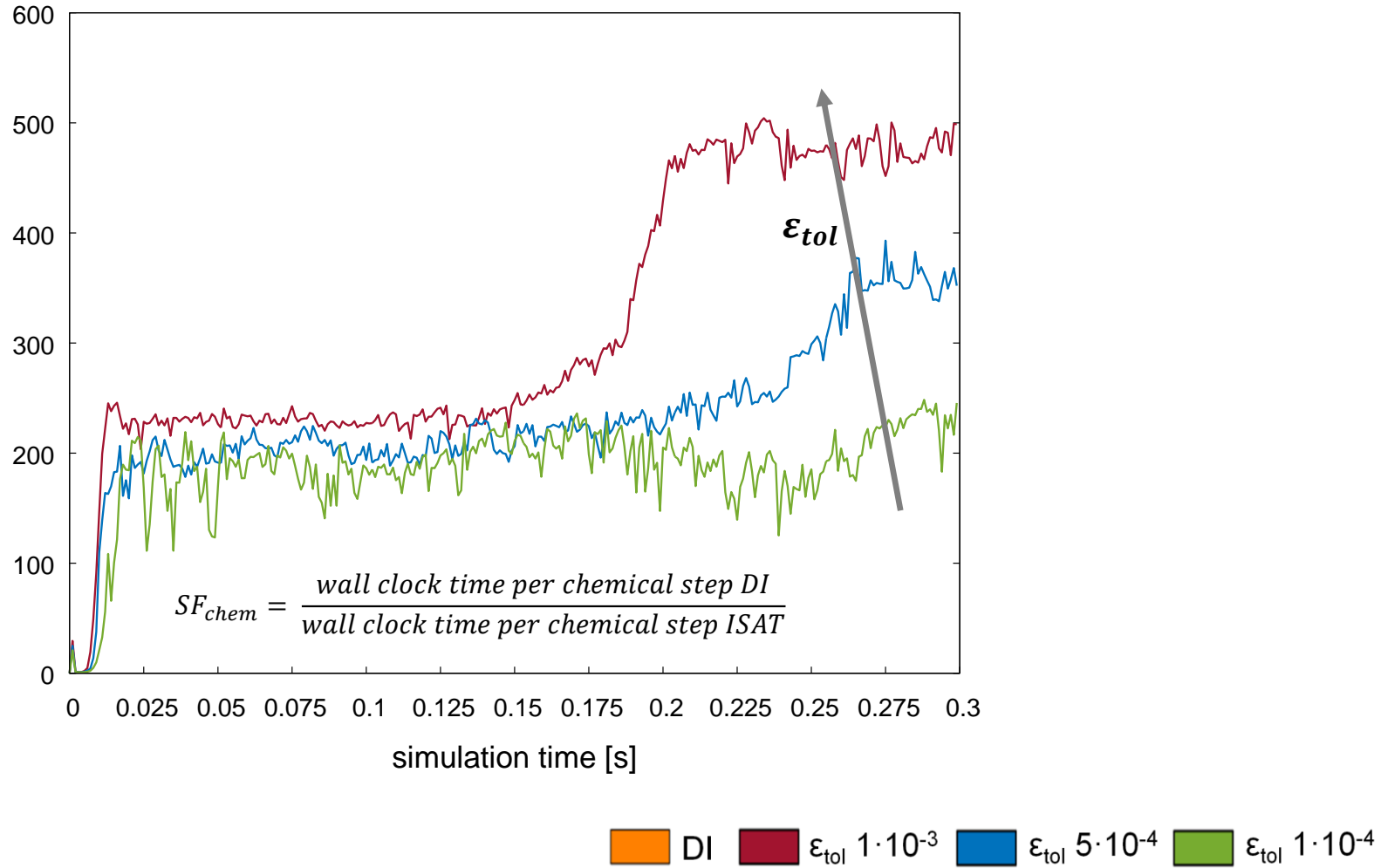

Computational efficiency

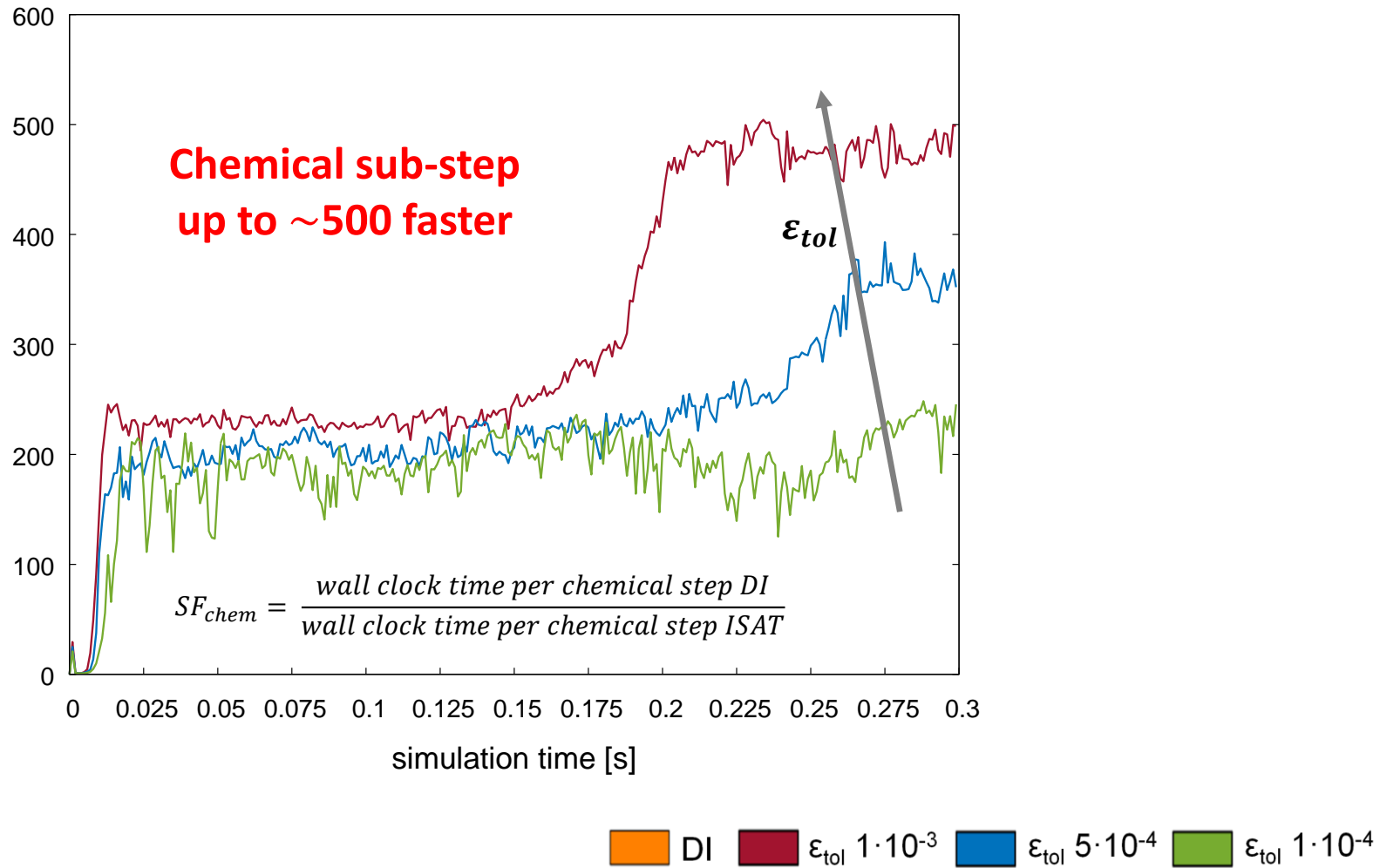

Computational efficiency

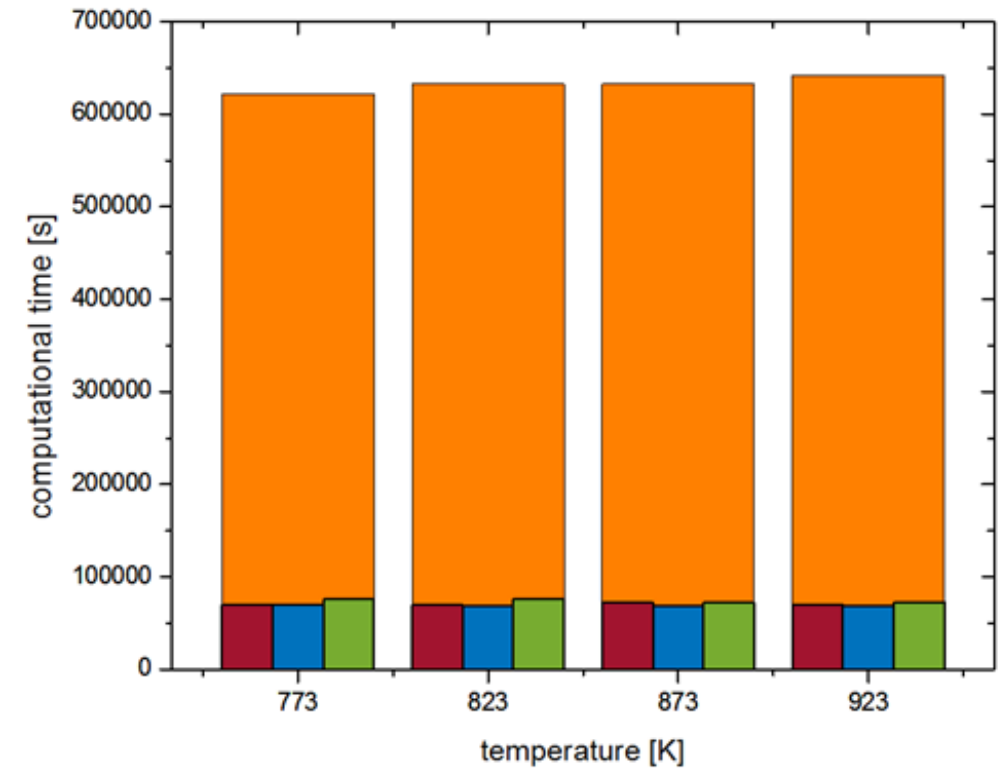
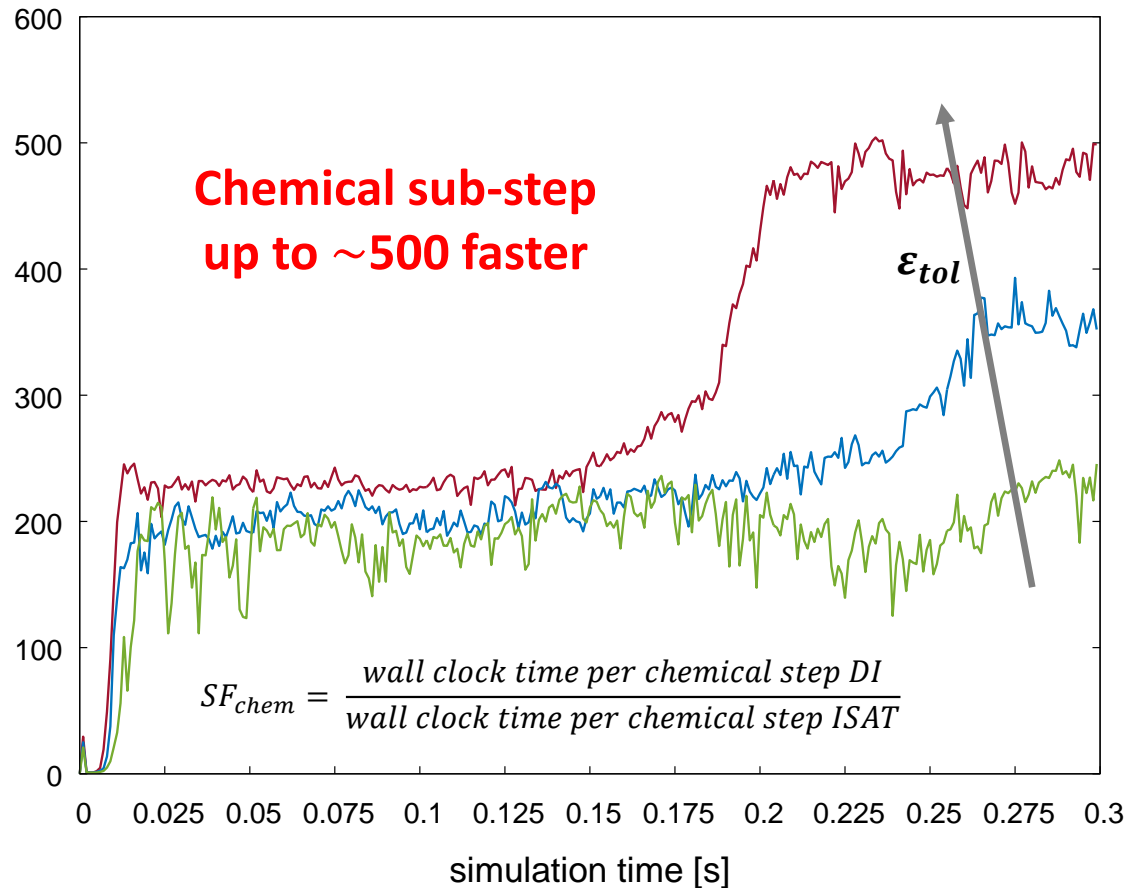

Computational efficiency

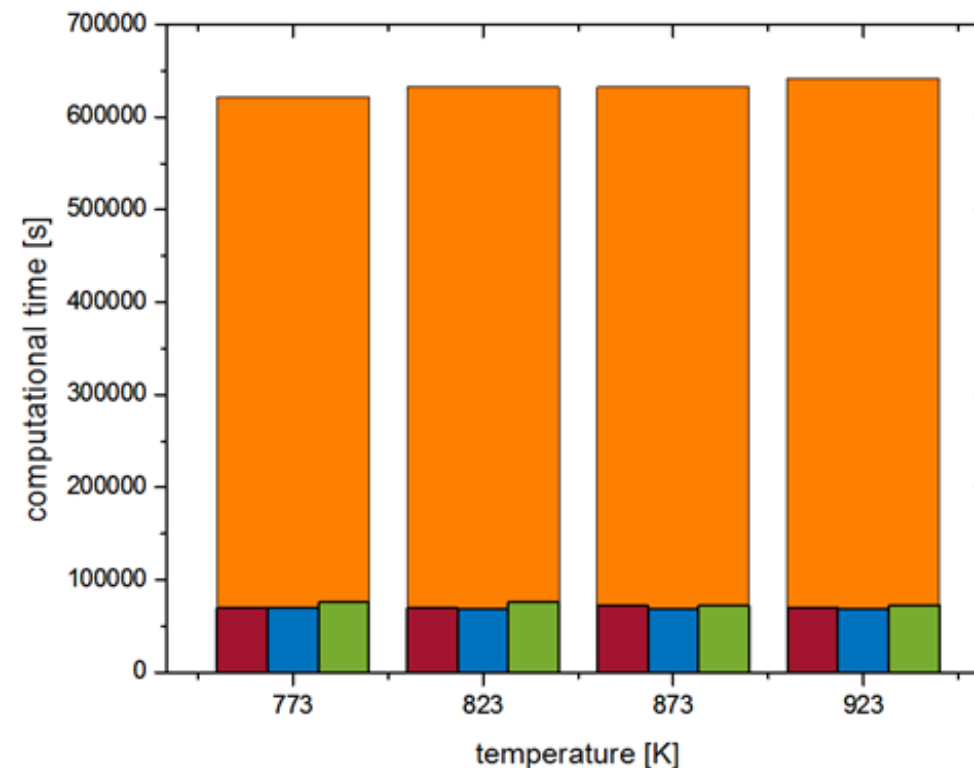
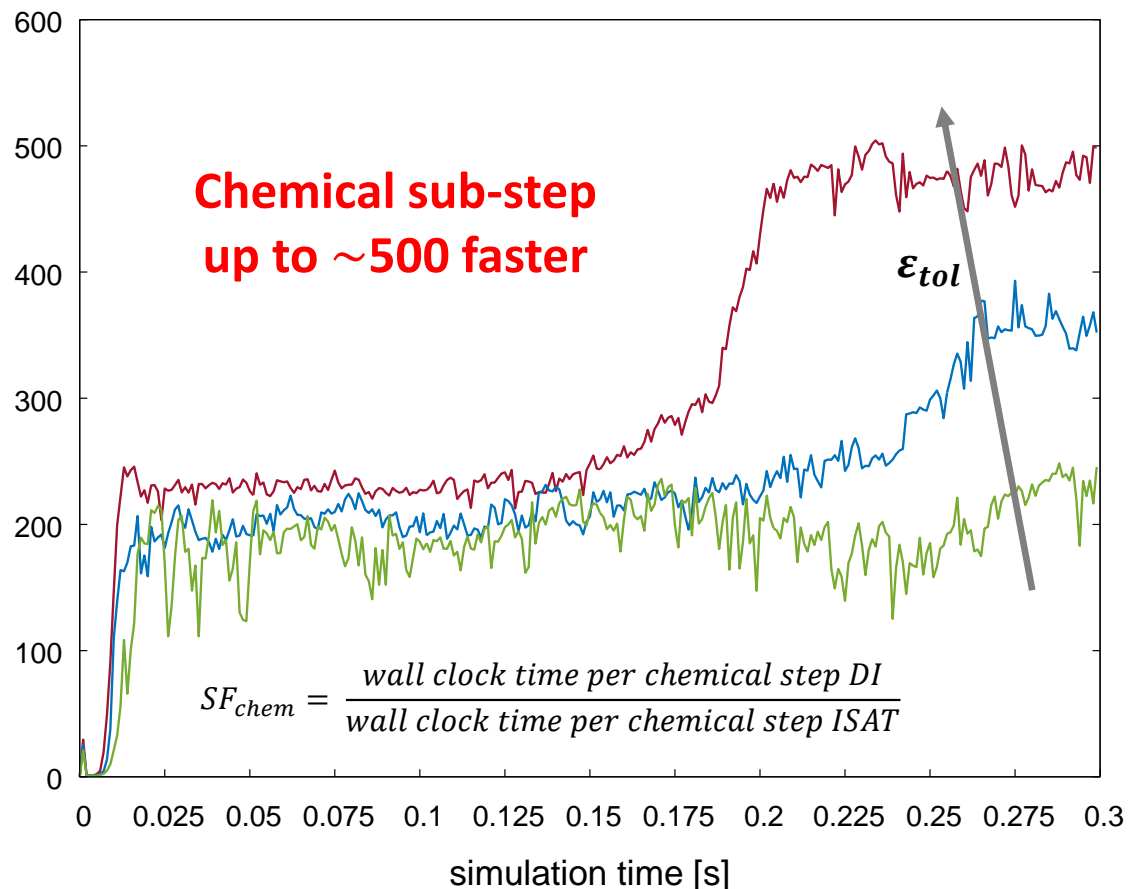

Overall computational time reduced up to ~5-15 times

■ DI
 ■ $\epsilon_{tol} 1 \cdot 10^{-3}$
■ $\epsilon_{tol} 5 \cdot 10^{-4}$
■ $\epsilon_{tol} 1 \cdot 10^{-4}$

Coming back to the packed bed reactor

Computational domain

- 25 particles
- 3D domain
- 500k mesh cells

Operative conditions

- Isothermal
- Feed velocity: 0.35 m/s
- H₂O/CH₄: 3.5 : 1

Micro-kinetics model

- 21 gas species
- 13 adsorbed species
- 80 surface reactions

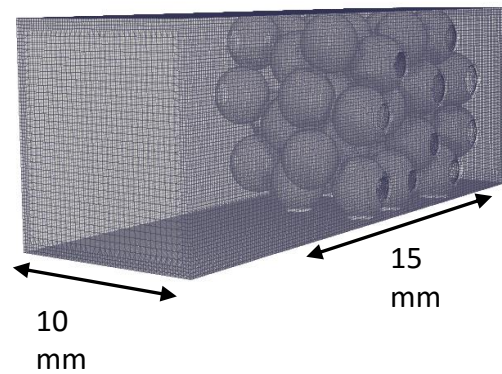

$$\epsilon_{tol} = 8 \cdot 10^{-4}$$

Time = 0.0015 s

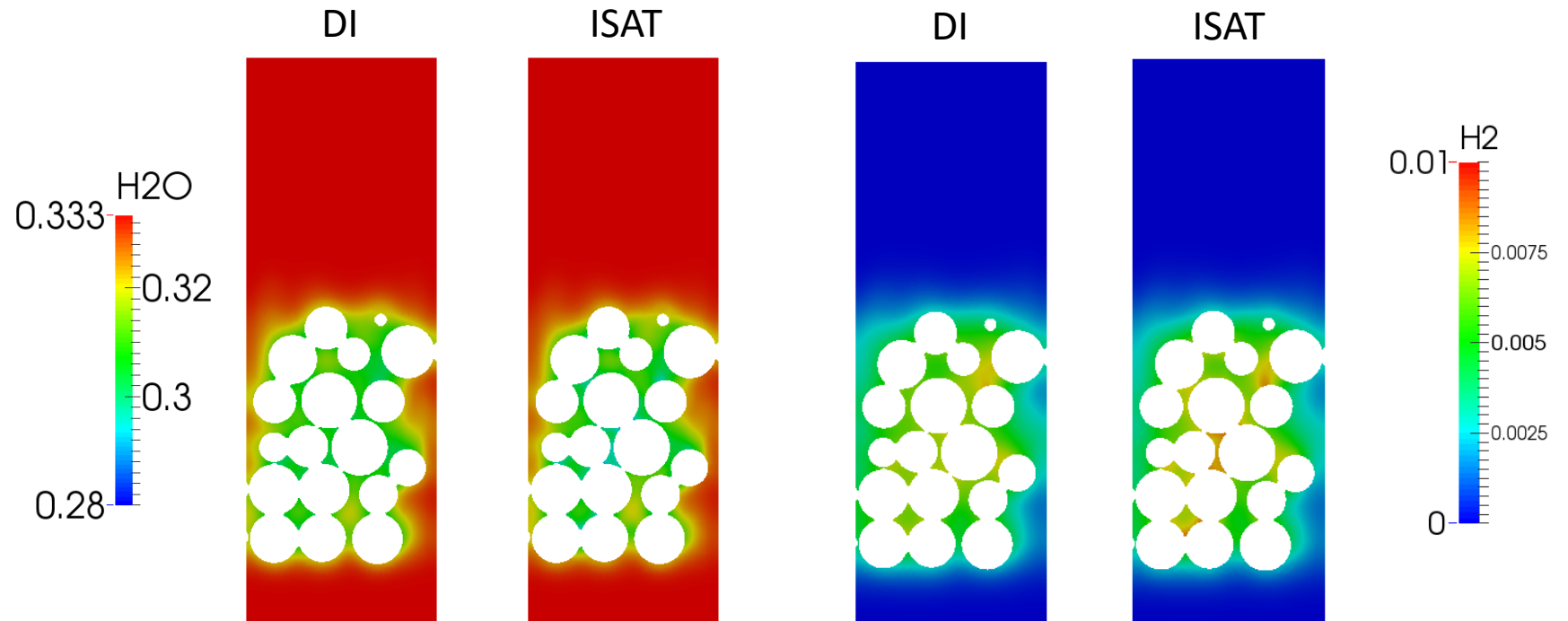

Coming back to the packed bed reactor

Computational domain

- 25 particles
- 3D domain
- 500k mesh cells

Operative conditions

- Isothermal
- Feed velocity: 0.35 m/s
- H₂O/CH₄: 3.5 : 1

Micro-kinetics model

- 21 gas species
- 13 adsorbed species
- 80 surface reactions

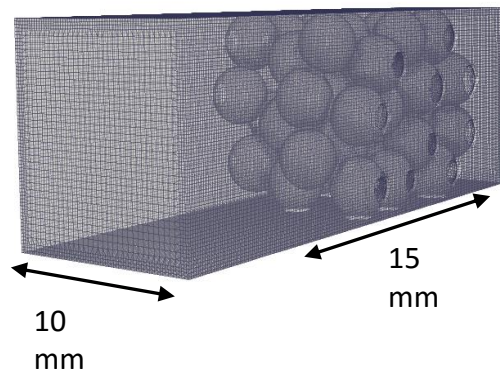

$$\epsilon_{tol} = 8 \cdot 10^{-4}$$

Time = 0.0015 s

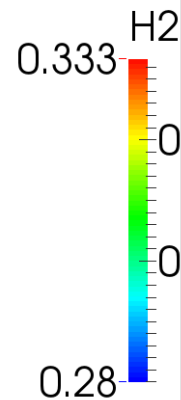

Simulation speed-up
15 times

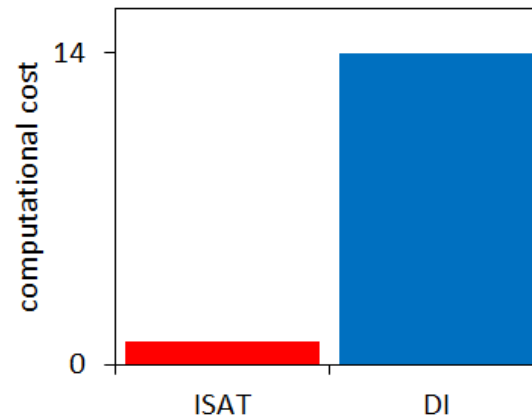

DI

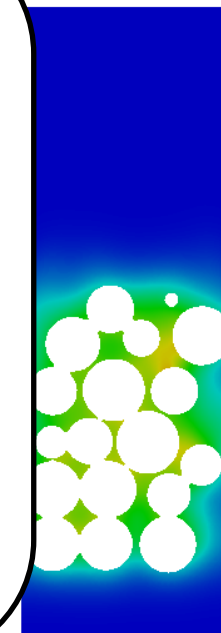

ISAT

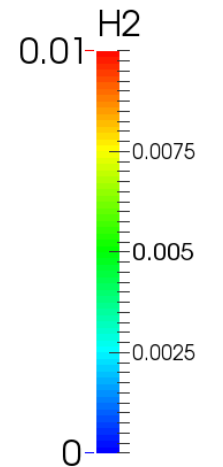
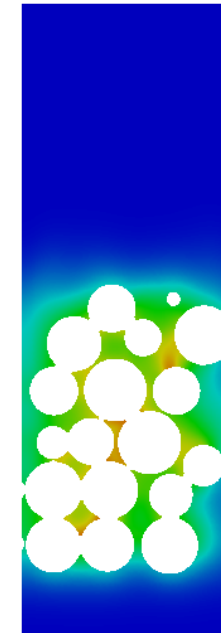

Taking into account intra-particle diffusion

Computational domain

- 25 particles
- 3D domain
- 1.1 Mio mesh cells

Operative conditions

- Adiabatic
- Feed velocity: 0.35 m/s
- H₂O/CH₄: 3.5 : 1

Micro-kinetics model

- 21 gas species
- 13 adsorbed species
- 80 surface reactions

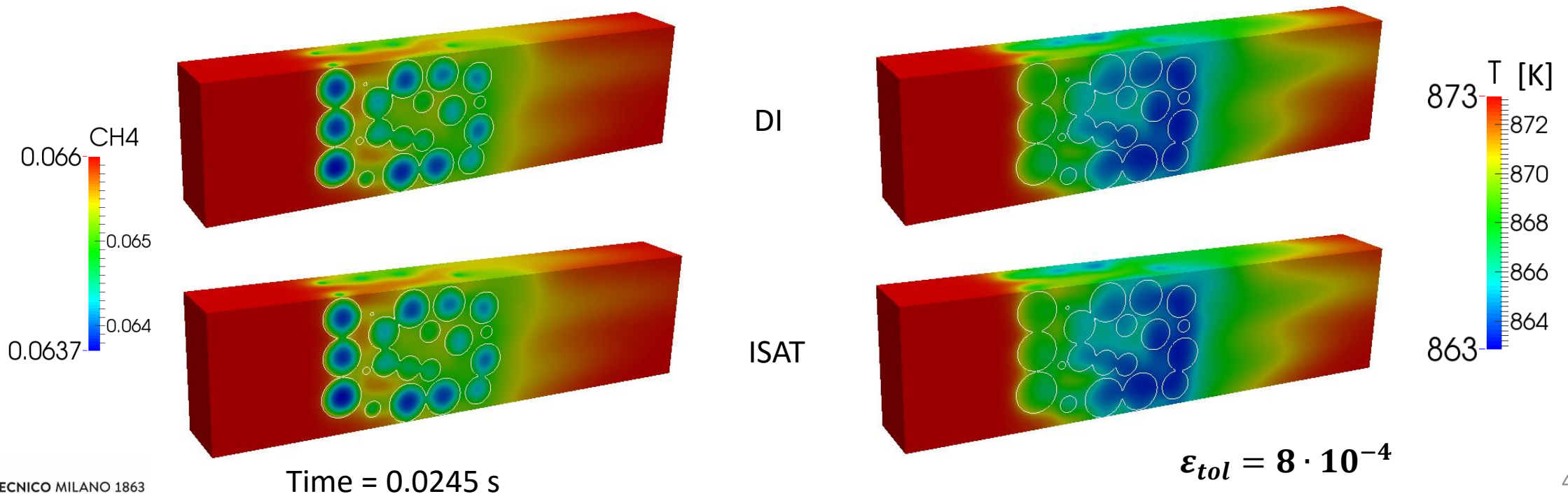

Taking into account intra-particle diffusion

Computational domain

- 25 particles
- 3D domain
- 1.1 Mio mesh cells

Operative conditions

- Adiabatic
- Feed velocity: 0.35 m/s
- H₂O/CH₄: 3.5 : 1

Micro-kinetics model

- 21 gas species
- 13 adsorbed species
- 80 surface reactions

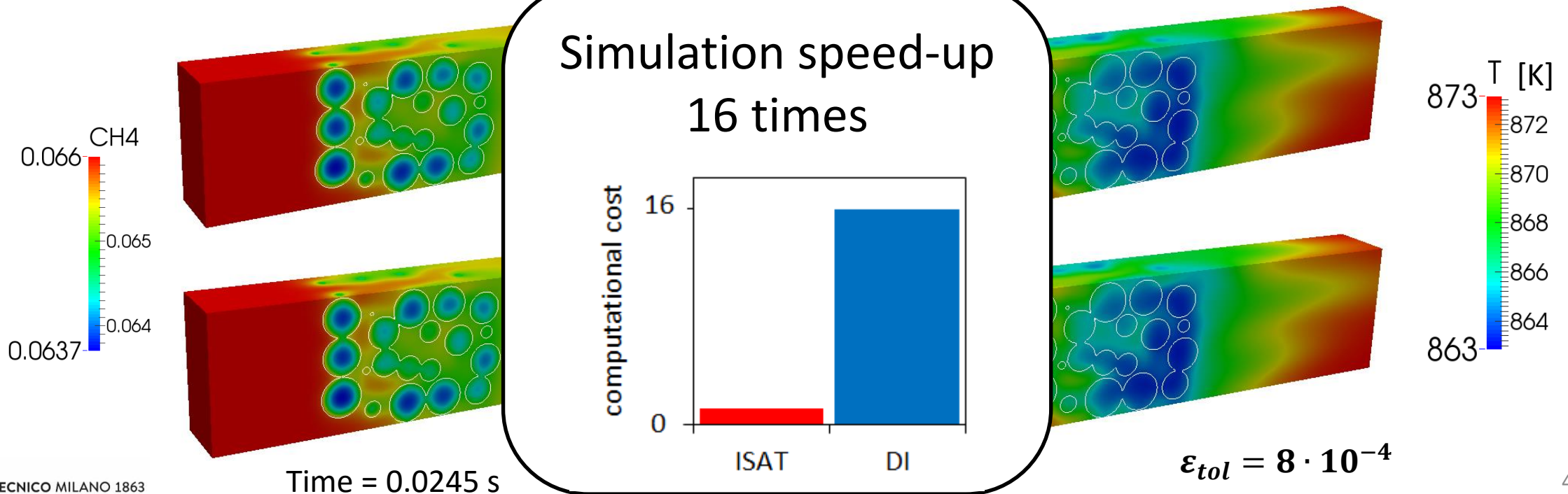

Conclusions

- ISAT algorithm has been applied for the to dynamic CFD simulations of heterogeneous reactors

Conclusions

- ISAT algorithm has been applied for the to dynamic CFD simulations of heterogeneous reactors
- A numerical strategy has been developed to implement the algorithm with dedicated solutions to deal with transient problems

Conclusions

- ISAT algorithm has been applied for the to dynamic CFD simulations of heterogeneous reactors
- A numerical strategy has been developed to implement the algorithm with dedicated solutions to deal with transient problems
- Good agreement between ISAT and DI

Conclusions

- ISAT algorithm has been applied for the to dynamic CFD simulations of heterogeneous reactors
- A numerical strategy has been developed to implement the algorithm with dedicated solutions to deal with transient problems
- Good agreement between ISAT and DI
- Simulation speed-up from 5 up to 16 times



THANK YOU FOR
YOUR KIND ATTENTION

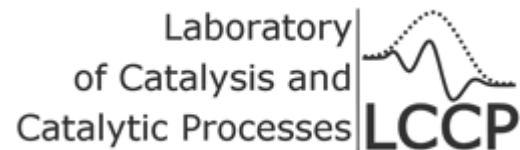

POLITECNICO
MILANO 1863



BACK-UP SLIDE

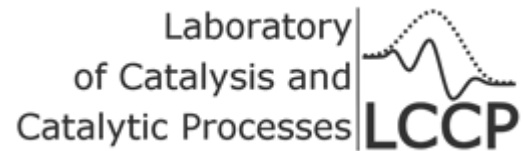

POLITECNICO
MILANO 1863

Species and coverage profiles along the circular reactor

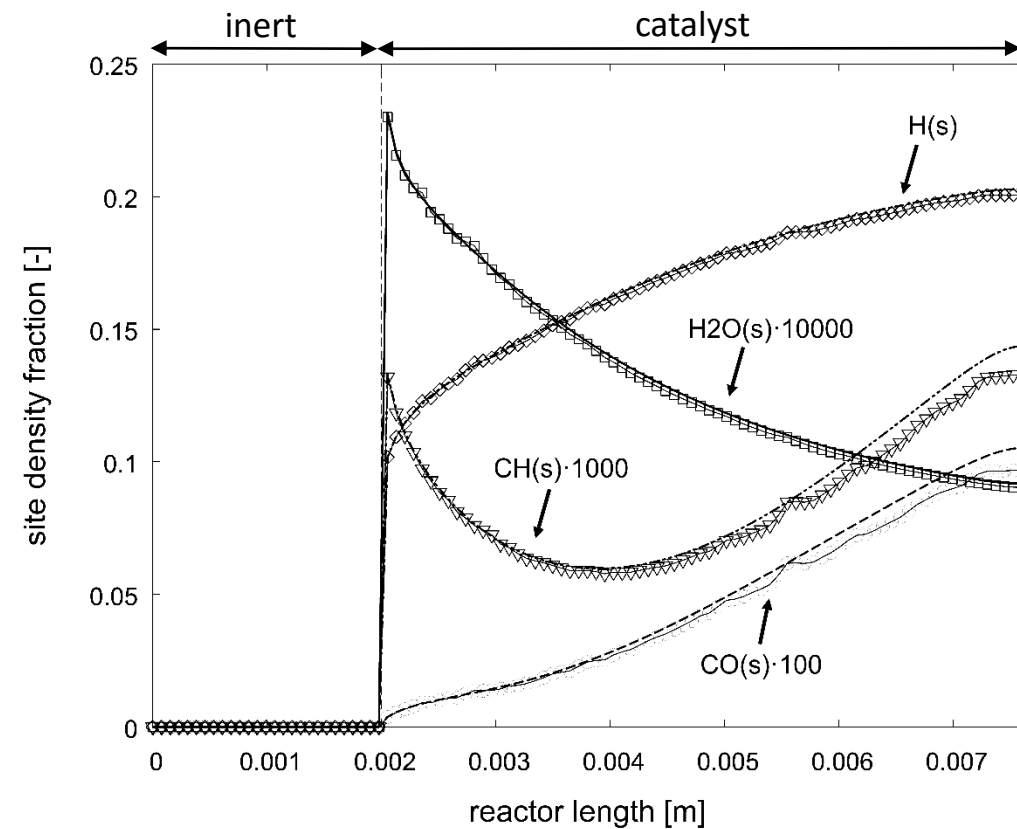
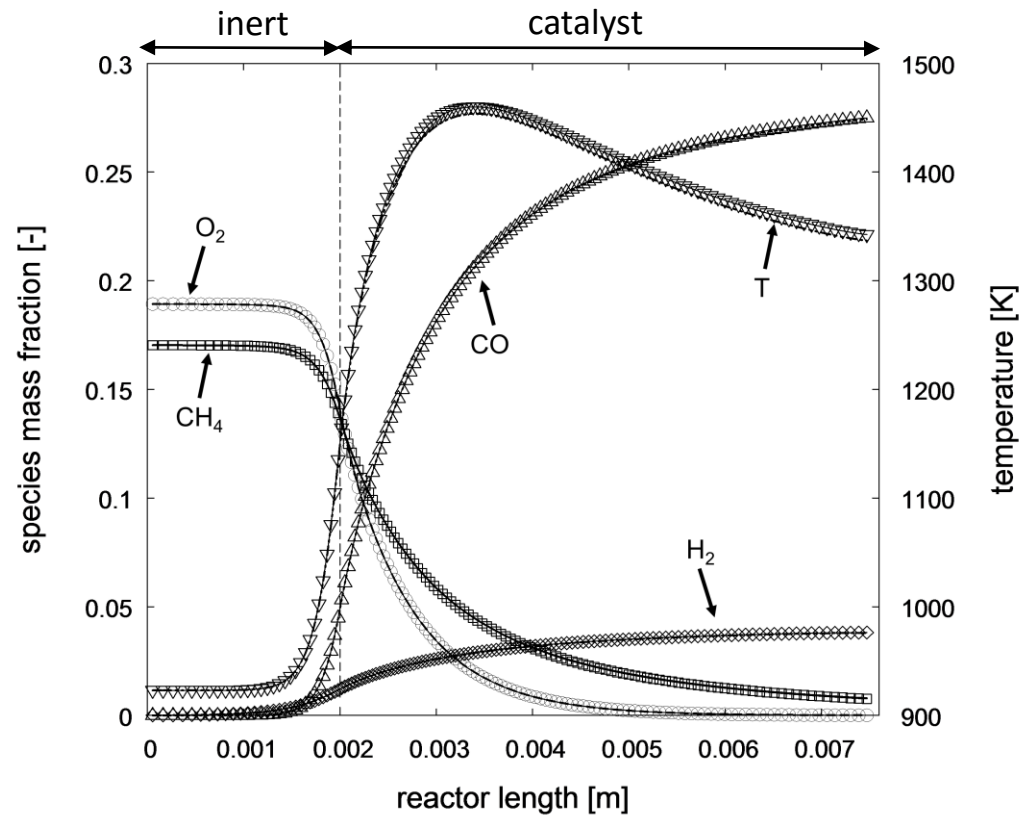

- ISAT and direct integration cup-mix profiles superimposed
- Good agreement in coverage predictions

Settling the table is the bottle-neck

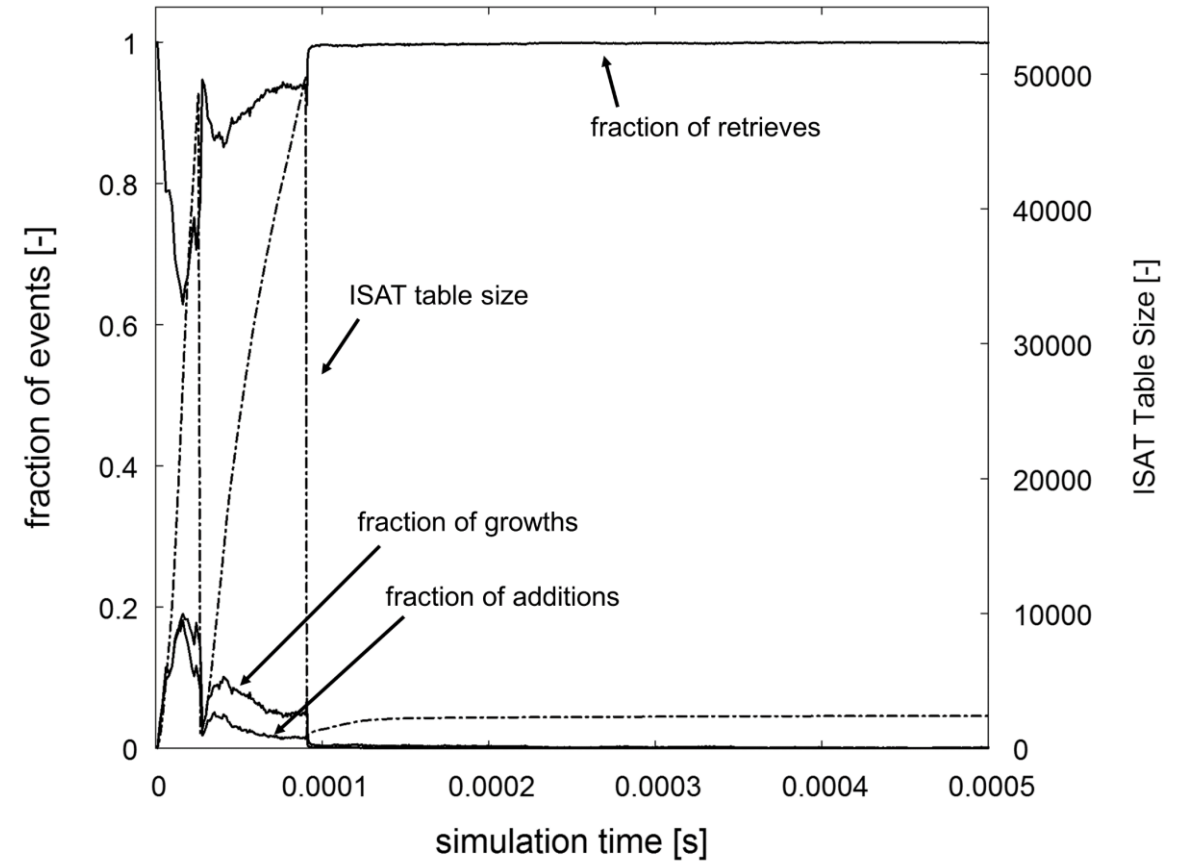
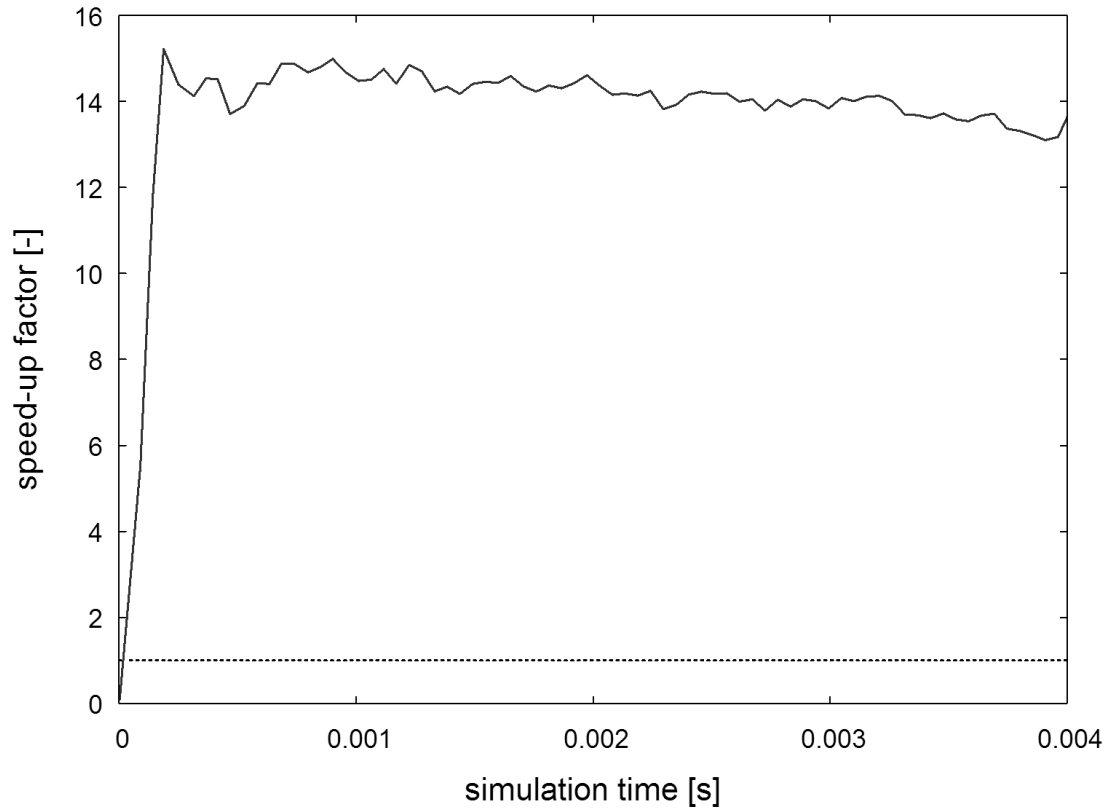

Taking into account intra-particle diffusion – ISAT final results

Computational domain

- 25 particles
- 3D domain
- 1.1 Mio mesh cells

Operative conditions

- Adiabatic
- Feed velocity: 0.35 m/s
- H₂O/CH₄: 3.5 : 1

Micro-kinetics model

- 21 gas species
- 13 adsorbed species
- 80 surface reactions

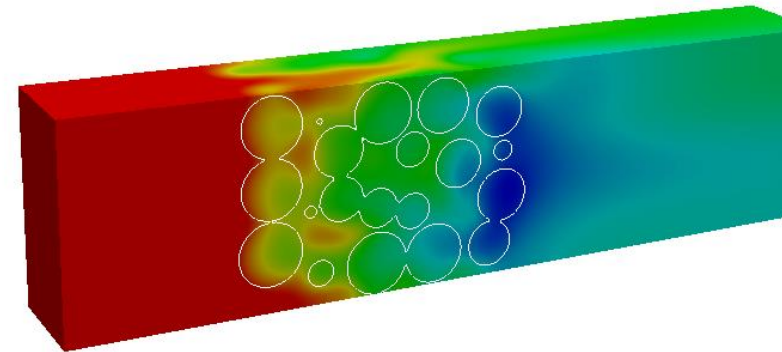
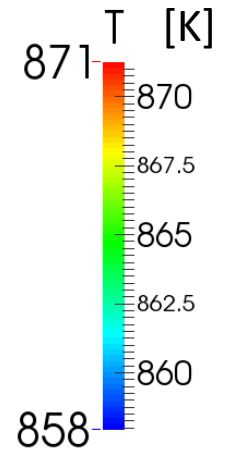
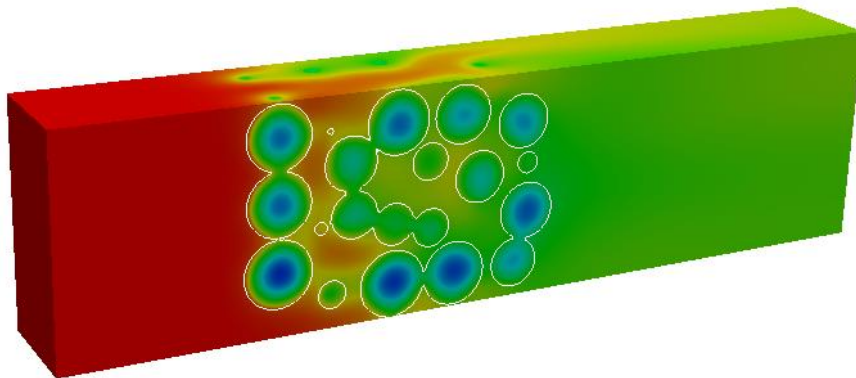
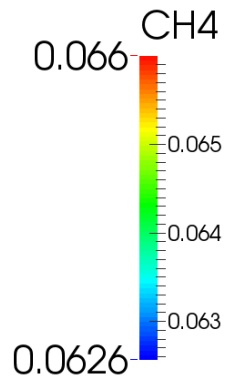

Time = 0.4 s

$$\epsilon_{tol} = 8 \cdot 10^{-4}$$

Large improvement when DI is computational more demanding

